

# **Report on As-Is Analysis and Standardized Process-Support to Odisha Renewable Energy Development Agency (OREDA) for proliferation of rooftop solar**

**Eco-cities in India program**

July 2017

*Strictly Not for Public Distribution*

In partnership with



**European Union**



*Creating Markets, Creating Opportunities*

This document has been prepared by Deloitte Touche Tohmatsu India LLP for IFC as part of Eco-cities program supported by the European Union.

**DISCLAIMER**

© International Finance Corporation 2017. All rights reserved.

The material in this work is copyrighted. Copying and/or transmitting portions or all of this work without permission may be a violation of applicable law. IFC does not guarantee the accuracy, reliability or completeness of the content included in this work, or for the conclusions or judgments described herein, and accepts no responsibility or liability for any omissions or errors (including, without limitation, typographical errors and technical errors) in the content whatsoever or for reliance thereon.

## Contents

<b>ABBREVIATIONS.....</b>	<b>5</b>
<b>1 EXECUTIVE SUMMARY .....</b>	<b>7</b>
<b>2 BACKGROUND.....</b>	<b>17</b>
2.1 OBJECTIVE OF ASSIGNMENT .....	17
2.2 SCOPE OF WORK .....	17
<b>3 INTRODUCTION.....</b>	<b>19</b>
3.1 POLICY AND PROGRAMS FOR SOLAR ROOFTOP IN INDIA.....	19
3.2 POLICY AND PROGRAMS FOR SOLAR ROOFTOP IN ODISHA .....	22
3.3 REGULATORY FRAMEWORK FOR SOLAR ROOFTOP IN ODISHA .....	24
<b>4 PROCESS FOR IMPLEMENTATION OF ROOFTOP SOLAR IN ODISHA .....</b>	<b>26</b>
4.1 KEY STAKEHOLDERS .....	26
4.2 BROAD PHASES FOR IMPLEMENTATION OF SOLAR ROOFTOP .....	28
4.2.1 Information Access .....	28
4.2.2 Application Process .....	31
4.2.3 Application Screening and System Feasibility .....	33
4.2.4 Project Installation .....	35
4.2.5 Connectivity and Synchronization .....	36
4.2.6 Subsidy Disbursement .....	36
4.2.7 Grievance Redressal Mechanism.....	37
4.2.8 Vendor Empanelment .....	38
<b>5 PROCESS FOR IMPLEMENTATION OF SOLAR ROOFTOP PROJECTS.....</b>	<b>39</b>
5.1 PROCESS FOR AVAILING SUBSIDY.....	39
5.2 PROCESS FOR AVAILING CONNECTIVITY .....	40
5.3 PROCESS FOR AVAILING BOTH SUBSIDY AND CONNECTIVITY .....	41
<b>6 PROPOSED PROCESS FOR IMPLEMENTATION OF SOLAR ROOFTOP THROUGH WEB APPLICATION .....</b>	<b>43</b>
6.1 PROCESS FOR AVAILING SUBSIDY .....	43
6.2 PROCESS FOR AVAILING CONNECTIVITY .....	44
6.3 PROCESS FOR AVAILING BOTH SUBSIDY AND CONNECTIVITY .....	45
6.4 INDICATIVE TIMELINES FOR PROCESSING OF APPLICATION WITH WEB APPLICATION .....	47
<b>7 ASSESSMENT OF OREDA’S IT ARRANGEMENTS.....</b>	<b>48</b>
7.1 EVALUATION OF THE EXISTING IT INFRASTRUCTURE AND SERVICES .....	48
7.2 EVALUATING EXISTING IT CONTRACTS.....	48
7.2.1 OREDA Customer Relationship Management Solution (CRMS) .....	48
7.2.2 OREDA Mobile Application (Proposal) .....	49
7.2.3 SMS Notification Feature (Proposal) .....	50
7.3 EVALUATING MANPOWER REQUIREMENT FOR PROGRAM IMPLEMENTATION .....	50
7.4 REVIEW OF EXISTING IT ARRANGEMENT KEY GAPS.....	51
7.4.1 Strength.....	51
7.4.2 Weakness.....	52
7.5 WAY FORWARD- SCOPING NEED FOR WEB TOOL. ....	53
<b>8 GAPS AND KEY RECOMMENDATIONS.....</b>	<b>53</b>

<b>9</b>	<b>ANNEXURE (EXISTING FORMATS)</b> .....	<b>57</b>
9.1	BEST PRACTICES - ROOFTOP SOLAR IMPLEMENTATION .....	57
9.1.1	<i>California (Rule 21) Interconnection Process</i> .....	57
9.1.2	<i>Germany Interconnection Process</i> .....	58
9.2	KARNATAKA INTERCONNECTION PROCESS .....	60
9.3	IMPLEMENTATION MODELS FOR ROOFTOP SOLAR .....	61
9.3.1	<i>Gross Metering Arrangement</i> .....	61
9.3.2	<i>Net Metering Arrangement</i> .....	61
9.3.3	<i>Evolution of Rooftop Solar Business Models</i> .....	62
9.4	EXISTING FORMATS FOR RTS IMPLEMENTATION .....	65

## LIST OF FIGURES

Figure 1: key Stakeholder in Odisha for Rooftop Implementation .....	8
Figure 2: Broad Phases for Implementation of Solar Rooftop .....	8
Figure 3: Current process for implementation of Rooftop Solar Project.....	11
Figure 4: Growth of Solar in Last five Years .....	19
Figure 5: Capacity additions under JNNSM (in GW) .....	20
Figure 6: MNRE state-wise targets for Solar Rooftops.....	21
Figure 7: Solar Rooftop target of Odisha.....	22
Figure 8: Institutional Structure of Power Sector in Odisha .....	26
Figure 9: key Stakeholder in Odisha for Rooftop Implementation .....	27
Figure 10: Broad Phases for Implementation of Solar Rooftop .....	28
Figure 11: Project Planning Phases.....	29
Figure 12: Estimation of Energy Yield and Energy Value in Bhubaneswar .....	29
Figure 13: Typical Project Costing of Solar Rooftop Project (Without Storage).....	30
Figure 14: Application Process .....	31
Figure 15: Odisha Application Process.....	32
Figure 16: Application Screening Process in Odisha.....	33
Figure 17: Application Screening at OREDA.....	34
Figure 18: Application Screening at Discom .....	34
Figure 19: Process of Project Installation .....	35
Figure 20: Project Connectivity Process in Odisha.....	36
Figure 21: Subsidy Disbursement to Beneficiaries .....	37
Figure 22: Process of Availing Subsidy and Timelines .....	39
Figure 23: Process for availing Connectivity of Rooftop System .....	40
Figure 24: Process flow for applicant availing Subsidy and Connectivity .....	42
Figure 25: Process flow for availing subsidy .....	43
Figure 26: Process for Availing Connectivity.....	44
Figure 27: Process flow for application for Connectivity and Subsidy.....	47
Figure 28: Organization Chart of OREDA .....	51
Figure 29: California Interconnection Process.....	57
Figure 30: Germany Interconnection process .....	58
Figure 31: BESCO Interconnection Process.....	60
Figure 32: Typical Gross metering arrangement.....	61
Figure 33: Typical Net metering arrangement .....	61
Figure 34: Evolution of Decentralized Solar PV Models.....	62
Figure 35: Rooftop solar Business models.....	64

## LIST OF TABLES

Table 1: Gaps and Recommendations.....	11
Table 2: Rooftop Solar target under Solar Policy, 2013 .....	23
Table 3: Guidelines for Change in City Bye laws.....	23
Table 4: Solar PV targets for different Consumer Categories.....	24
Table 5: Indicative Timelines for Subsidy Disbursement .....	39
Table 6: Indicative Timelines for Connectivity .....	41
Table 7: Indicative timelines for Connectivity and Subsidy Application.....	42
Table 8: Gaps in Odisha Rooftop Implementation Framework.....	53

## Abbreviations

Abbreviation	Description
AC	Alternating Current
CEA	Central Electricity Authority
CERC	Central Electricity Regulatory Commission
CFA	Central Financial Assistance
CSS	Cross Subsidy Surcharge
CUF	Capacity Utilization Factor
DC	Direct Current
DG	Distributed Generation
DTR	Distribution Transformer
EE	Executive Engineer, Discom
FY	Financial Year
GBI	Generation Based Incentive
GHG	Green House Gases
GHI	Global Horizontal Irradiation
GM	Gross Metering
GoI	Government of India
GoO	Government of Odisha
GW	Giga Watt
HV / HT	High Voltage/ tension
IEEE	Institute of Electrical and Electronics Engineers
IEGC	Indian Electricity Grid Code
IPP	Independent Power Producers
IREDA	Indian Renewable Energy Development Agency
IRENA	International Renewable Energy Agency
JNNSM	Jawaharlal Nehru National Solar Mission
kVA	Kilo Volt Ampere
kW	Kilo Watt
kWp	Kilo Watt Peak
LV /LT	Low Voltage/ Tension
MNRE	Ministry of New and Renewable Energy, India
MRT	Meter Reading and Testing Division, Discom
NAPCC	National Action Plan on Climate Change
NASA	National Aeronautics and Space Administration
NISE	National Institute of Solar Energy
NM	Net Metering
NREL	National Renewable Energy laboratory
NTPC	National Thermal Power Corporation
O&M	Operation and Maintenance
OREDA	Odisha Renewable Energy Development Agency
OERC	Odisha Electricity Regulatory Commission

<b>Abbreviation</b>	<b>Description</b>
OPTCL	Odisha power transmission corporation limited
OREDA CRC	OREDA Customer Relationship Center
PFA	Power for All
PPA	Power Purchase Agreement
PSU	Public Sector Utilities
PV	Photovoltaics
R&D	Research and Development
RE	Renewable Energy
RESCO	Renewable Energy Service Company
RTS	Rooftop Solar
RPO	Renewable Purchase Obligation
RPSSGP	Rooftop PV & Small Solar Power Generation Program
SDG&E	San Diego Gas and Electric
SERC	State Electricity Regulatory Commission
SRT PV	Solar Rooftop PV
SNA	State Nodal Agency
T&D	Transmission and Distribution
TOD	Time of Day
WACC	Weighted Average Cost of Capital

## 1 Executive Summary

Government of India (GOI) is driving an ambitious solar program of achieving 100 GW of solar power by 2022. This would include development of both large and small scale projects across the country. Solar rooftop can play an important role in achieving this target as it is easily implementable on vacant roof spaces without any hassle of land acquisition and evacuation infrastructure. Recognizing benefits of rooftop solar (RTS), GOI is emphasizing on developing RTS projects and has set a target of 40 GW for RTS within 100 GW target.

To make RTS projects more affordable and feasible for end consumers in India, MNRE has launched several schemes to provide capital support, incentives, tax exemptions, soft loans etc. for implementation of RTS projects and is continuously improving the policy framework at central level. To support rooftop solar projects, a number of states are also incentivizing rooftop solar systems through capital support and conducive regulatory environment.

Govt. of Odisha is also implementing measures to promote solar power through RTS projects under different RE policy, Smart City and Solar City program. Development of RTS system has always been a focus area for Odisha and it is promoting grid interactive roof top solar power projects ranging from 0.5 KW to 500KW for different Government, semi Government and Non-Government institutes as well as private households with the objective of saving day time peak power requirement, reducing AT&C loss and improve voltage. Odisha RE policy 2016 has a target of 2,200 MW of solar capacity including 1,000 MW from solar rooftop by the year 2022; Bhubaneswar Solar City plan also envisage development of 1.8 MW of solar PV for residential apartments for saving of approximately 2.7 MU of energy and 2,187 tons of carbon emissions. The solar strategies prepared for residential sector would help in achieving 29% of the total target which is 157.01 MU of energy. Similarly under the smart city program, Bhubaneswar has a target of consuming 10% of total power through solar power, which is to be generated through large ground mounted utility scale and small distributed rooftop solar projects.

Policy and Regulatory framework plays an important role, however actual implementation of RTS require a simple and streamlined implementation framework, which is lacking in most parts of the country. Due to cumbersome process and difficulties in getting approvals from distribution utilities, state nodal agencies, electrical inspector etc, there is a huge gap in envisaged targets and commissioned capacity for solar rooftop in India.

To overcome these gaps, this report endeavors to highlight the need for adoption of an effective framework to get necessary approvals and connectivity for rooftop solar project in State of Odisha. Odisha has a target of achieving 1 GW of rooftop capacity by 2022. Further, OERC (Odisha Electricity Regulatory Commission) has also issued regulatory framework for development of solar rooftop in the State. However, till now the growth of rooftop solar is quite low in the State. This is primarily due to lack of proper information channels, application processing framework and multiple approvals required for implementation of RTS projects.

This challenge can be resolved by integrating all key stakeholders involved in development of solar rooftop under single platform. This would first require clearly defining the role, responsibilities and timelines of each stakeholder and then to standardize the complete process of implementation.

**Figure 1: key Stakeholder in Odisha for Rooftop Implementation**

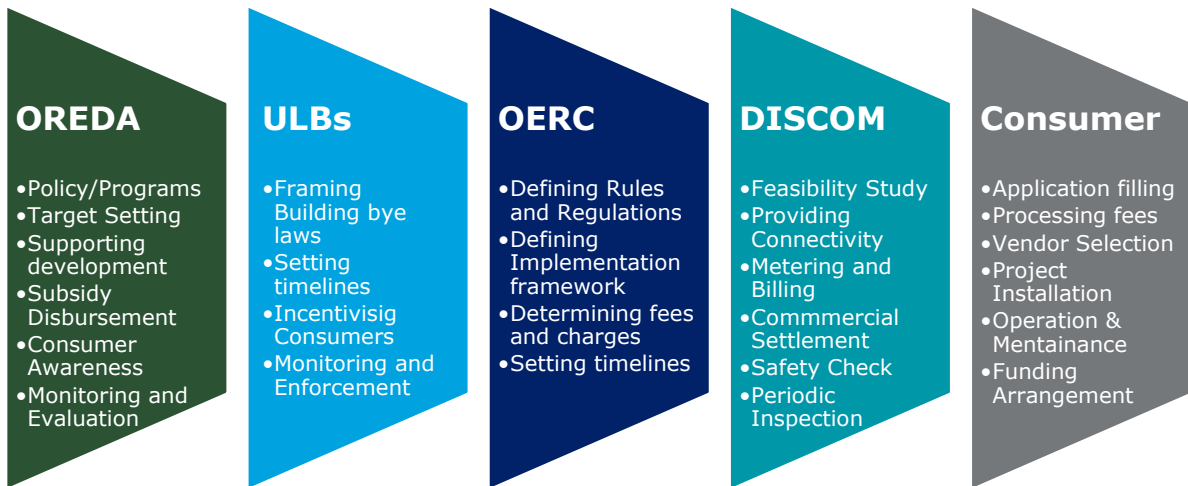

Standardization of rooftop solar implementation process would require in-depth analysis of current process with respect to project registration, application processing, site inspection, subsidy disbursement, connectivity etc. followed by the implementing agencies in Odisha. Mapping of complete process followed in Odisha is done based on the eight broad steps for implementation of solar rooftop as illustrated below

**Figure 2: Broad Phases for Implementation of Solar Rooftop**



1. **Information Access** – Information Access is the process of providing relevant and required information to applicant through multiple communication channels, so that applicant can collate the all the required information with ease and can proceed to next phase i.e. Application Process. As a best practice, this phase should be able to educate applicant on following things

- a. Relevant Policies and Regulatory Framework
- b. Project Sizing and Resource Assessment
- c. Required approvals and clearances
- d. Key Equipment and Costing

- e. Certified System Installers
- f. How to access pre-feasibility
- g. Business Models and Project financing etc.

As per the existing framework, OREDA through OREDA Customer Relationship Centre (CRC) provides required information to applicants through web portal or helpline numbers. OREDA CRC facilitates applicants in providing following information.

- a. Information on RTS System
- b. Key Components of RTS system
- c. Subsidy/CFA (%) for installation of RTS System
- d. List of frequently asked Questions
- e. Pre-requisite's for installing RTS System
- f. Rooftop Calculator/ Application Submission Platform
- g. Application form (for offline submission)
- h. Regulatory provisions for Installing RTS System
- i. List of Empanelled Vendors by OREDA
- j. Grievance Redressal Mechanism

In addition to this, applicants can also reach out to Discom Head Office/Divisional Office to get the relevant information, forms/formats required for installation of solar rooftop projects in Odisha.

2. **Application Process:** Application process basically involves, two sub processes i.e. Application access and Application Submission. It is important for implementing agencies as it generally involves manpower and cost associated to it. By adopting best practices, implementing agencies can improve process to access, complete and submit the application form for applicants and bring efficiency to the whole process by reducing application processing time.

As per the existing framework in Odisha, application process involves processing of application by concerned distribution utility for grid connectivity. If the applicant is eligible for subsidy and intends to apply for the same, then application process also involves OREDA for approval and disbursement of subsidy. Based on the application sent to OREDA or DISCOM, these agencies process the application accordingly. Application process of OREDA or Discom is detailed below.

- At Discom, application access and submission is done offline. Applicant also has the option to download the application form through OREDA CRC but the submission of application is through offline mode only. Dully filled application form is to be submitted to the sub-divisional office of concerned discom along with all the supporting documents
  - On submission of application form along with all necessary documents, general screening is done by the Division Office and on successful clearing of general screening application is registered with acknowledgement to the applicant.
  - In addition to grid connectivity, if an applicant is eligible for subsidy and intends to avail it then he/she needs to apply to OREDA in addition to discom. For this both online and offline process is available. Applicant can download the application form from OREDA CRC and submit it to OREDA head office, it can also submit the application through OREDA CRC web portal. On registration, applicant gets confirmation notice from OREDA on its registered email ID with list of all the empaneled vendors and steps to be followed for further processing of application. On successful registration of application, empaneled vendors also gets applicant details for communication.
3. **Application Screening and System Feasibility:** Application screening process typically involves review of generic components of application. Once the application clears the general screening, it is processed for technical screening wherein the application is examined on the basis of technical parameters, interconnection study, system impact studies etc. Technical screening is generally performed by distribution utilities with an objective specifically to check whether the proposed rooftop system is technically feasible and safe to connect with the distribution grid.

In Odisha, application screening happens at two places i.e. at OREDA and at Discom level. OREDA performs general screening of application process to check the feasibility of rooftop system for subsidy. Discom performs both general and technical screening in view of system safety.

The objective of application screening at OREDA is to check the correctness or completeness of application form and the eligibility of applicant for subsidy. After application clears general screening then OREDA officials undertake site inspection to check the roof size, shadow free area, proposed capacity etc. to check the feasibility of rooftop solar system.

At Discom level, application screening is done both at generic level and technical level. On clearing of generic screening in terms of application completeness and correctness, discom undertakes a detailed feasibility check at proposed site. The objective of the feasibility check is to assess the proposed rooftop project based on technical parameters such as contracted load, transformer loading, metering details etc. Feasibility check is done jointly by divisional manager, E&MR and MRT Officers within seven days of receiving application. Technical feasibility report is finally submitted to discom head office for issuance of permission of NOC. On scrutiny of technical feasibility report, discom head office gives permission to divisional manager for issuance of permission (NOC) if it is found technically feasible.

4. **Project Installation:** *On clearing the general and technical screening, applicant gets go-a-head signal from distribution utility for project installation. Project installation is the responsibility of applicant, wherein applicants identify and select appropriate vendor for system installation. Project installation also involves project procurement, wherein applicant or selected vendor on behalf of applicant does procurement of project equipment.*

Similar process is followed in Odisha for project installation. Applicant on getting the NOC from discom, selects appropriate vendor for project installation. On completion of project installation, applicant with supporting documents request the discom for grid connectivity.

5. **Connectivity and Synchronization:** *Connectivity and synchronization is final step of interconnection process. It holds high importance for applicant as well as distribution utility in terms of system safety and quality of power. The objective of this activity is to ensure that rooftop system is following the compliance with respect to measures for protection and islanding, phase sequencing, frequency and voltage variation compliance, DC injection etc.*

In Odisha, discom officials on receiving the work completion report, intimates the applicant for site visit to conduct the testing, commissioning and synchronization of the solar rooftop system. This is carried out by the concerned Sub-divisional/divisional Engineer along with MRT staff and E&MR staff within 8 days from the date of submission of completion report. During this step, solar rooftop system is thoroughly checked by E&MR and divisional manager prior to the commissioning and synchronization of the solar rooftop system with discom grid.

On successful testing of synchronization, a letter of synchronization is issued to the applicant by discom's Executive Engineer and a copy of the same is forwarded to discom head office for project inclusion under net metering register and further metering, billing and settlement mechanism.

6. **Subsidy Disbursement:** *Subsidy disbursement is the final step of project completion and is considered as the most cumbersome process due to lengthy approvals and processing time. Due to approval of various levels, availability of funds, status of subsidy disbursement is not adequate in the country. To improve this situation, MNRE has recently sanctioned and allowed state nodal agencies to disburse on their own.*

In Odisha, OREDA has the authority to disburse subsidy if the project clears all the general and technical screening process. Applicant post installation of project submits a copy of work completion report to OREDA and requests for site inspection. Site inspection is carried out by Assistant Director OREDA of concerned district. On satisfactory result of site inspection AD, OREDA submit the joint inspection report (OREDA, System Installer and Applicant) to the nodal officer at OREDA head office for further processing of subsidy application. On satisfactory results of joint inspection report, OREDA releases the subsidy to beneficiary's account.

7. **Grievance Redressal Mechanism:** *Grievance Redressal Mechanism is the key process in the whole project implementation cycle. It combines all the process and provide support to end consumer on reporting,*

processing and resolution of grievances with respect to solar rooftop implementation process including information access, application process, vendor selection, subsidy disbursement etc.

In Odisha, Consumer Grievances are addressed and recorded through OREDA CRC web portal. OREDA CRC also has 24X7 helpline number to resolve the queries/ complaints of consumers with respect to rooftop solar. All the grievances are recorded and resolved on through call centers and if the consumer is not satisfied then it is escalated to the nodal person at OREDA. Weekly report is also generated to check the status of grievances registered and resolved with timelines for resolution of grievances.

**Figure 3: Current process for implementation of Rooftop Solar Project**

The overall time taken for availing subsidy in Odisha is expected to be around 80 days from the date of receiving application. This includes the overall process of registering solar rooftop system at discom, installation and commissioning of system and sharing required information/ documentation to OREDA.

While, Odisha discom takes around 75 days for providing the connectivity to rooftop solar system. This includes application process, feasibility study, project installation, test inspection, synchronization and charging by discom.

As a best practice, it is always advisable to reduce the processing time by continuously monitoring and reviewing the complete process. This helps in bringing the efficiency and reducing soft cost incurred in the process of project installation and connectivity. Based on industry best practice to address the gaps in existing framework and the proposed recommendations are as follows.

**Table 1: Gaps and Recommendations**

S. No	Key Steps	Gaps and Recommendations
1.	Information Access	<ul style="list-style-type: none"> <li>In the existing framework of OREDA CRC, applicant has limited information with regards to installation of solar rooftop.</li> <li>Information access is an important phase of project implementation and applicant should be available with all the required information with regards to                             <ul style="list-style-type: none"> <li>Project Planning</li> <li>Resource Assessment</li> <li>Description of Key Equipment</li> <li>Standards and Specifications of Equipment</li> </ul> </li> </ul>

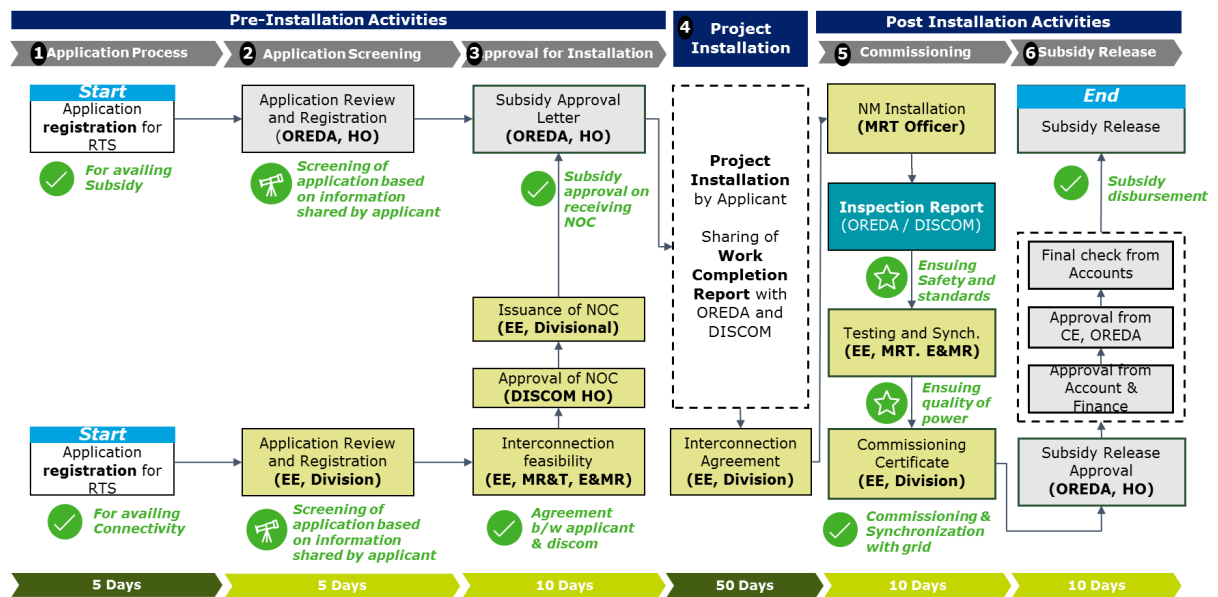

---

	<ul style="list-style-type: none"> <li>○ Cost Economics</li> <li>○ Project financing</li> <li>○ State and Central Govt. Schemes</li> <li>○ List of vendors with price quotation for different size of projects etc.</li> </ul>
	<ul style="list-style-type: none"> <li>● <b><i>As a best practice, there should be a platform where an applicant can gather all the required information with respect to system planning and implementation of the same in Odisha.</i></b></li> </ul>
2. Application Process	<ul style="list-style-type: none"> <li>● In the existing framework, Application access is online but submission of application is still manual at discom end.</li> <li>● Submission of application at OREDA is online however, remaining process is done manually.</li> <li>● <b><i>Industry best practice suggests that application process should be completely online ( application access, submission)</i></b></li> <li>● Further, In the existing framework, applicant has to file separate application to OREDA for subsidy and to CESU for connectivity</li> <li>● <b><i>A single web-portal, from where application can be submitted and downloaded by all the required agencies (OREDA, CESU, and BMC) is highly recommended.</i></b></li> <li>● <b><i>At present there is no provision of online payment, Applicant should also be allowed to submit the processing fee through online mode.</i></b></li> <li>● <b><i>As per the current practice, there is no integration of OREDA, CESU and BMC, which is still to be explored</i></b></li> </ul>
3. Application Processing	<ul style="list-style-type: none"> <li>● As per the current practice OERDA goes for site inspection twice before and after project installation.</li> <li>● <b><i>To reduce the processing time and simplify the process, OREDA may consider Utility NOC as a proof of feasibility of rooftop system for issuance of subsidy approval letter.</i></b></li> <li>● <b><i>Later on, OREDA may go for site inspection jointly with utility during connectivity and synchronisation of solar rooftop before release of subsidy</i></b></li> <li>● <b><i>In the existing framework, there is no provision of online approvals (both at OREDA and discom), adoption of which could help in reduction of application processing time and also reducing administrative burden</i></b></li> </ul>
4. Feasibility Study	<ul style="list-style-type: none"> <li>● As per the current practice, Discom officials performs interconnection feasibility study both before and after the installation of project</li> <li>● This increases the processing time, moreover before installation of project, feasibility study (interconnection study) can be carried out without site inspection</li> </ul>

---

	<ul style="list-style-type: none"> <li>• <b>Best practice should be to adopt one time Interconnection feasibility study post installation of rooftop projects</b></li> <li>• <b>Further, for fast track application approval utility may also consider to omit the requirement of feasibility study for those consumer who are installing projects through selected/ empanelled vendors.</b></li> </ul>
5. Interconnection Agreement	<ul style="list-style-type: none"> <li>• As per the current practice, discom has to sign interconnection agreement with applicant before starting project installation work</li> <li>• <b>By introduction of fast tract process, wherein projects below certain capacity say 10 kW are not required to sign interconnection agreement can reduce the time for processing of application</b></li> <li>• <b>Discom could also make interconnection agreement as a part of application form (for small consumers) so that the requirement of signing interconnection agreement can be omitted.</b></li> </ul>
6. Subsidy Disbursement	<ul style="list-style-type: none"> <li>• As per the current practice there is no provision of subsidy disbursement through online mode.</li> <li>• <b>OREDA is recently planning to launch online subsidy process, which can be linked with AADHAR card so that subsidy amount can be directly transferred to beneficiaries account</b></li> </ul>
7. Metering and Billing	<ul style="list-style-type: none"> <li>• Discoms' Current Metering and Billing practice is not in line with net metering scheme, which is creating a huge confusion among rooftop consumers regarding settlement of excess power</li> <li>• Further, in Odisha billing is still done manually by utility officers, which increases administrative burden and also reduces billing efficiency</li> <li>• <b>Discoms' needs to upgrade their billing software to make it compatible with Net metering scheme</b></li> <li>• <b>AMR enabled meters and reading machines must be deployed to reduce the possibility of dispute in commercial settlement of net metering bill.</b></li> </ul>
8. Vendor Empanelment	<ul style="list-style-type: none"> <li>• As per the current practice, empanelled vendors are not required to quote price of rooftop system and also the key component manufacturers they will be providing in given price range</li> <li>• <b>Best practice in this should be to seek price quotations from empanelled vendors based on capacity of the project such as (1-10 kW), (10-100 kW), (100-500 kW) as per MNRE guidelines for key components (Modules, Inverter, Meter etc.) every six months</b></li> </ul>

Considering the gaps identified above, it is required to create a new integrated web application, which is robust, secure, dynamic, stakeholder interactive and multi-faceted. The web application that integrates all key stakeholder viz. OREDA, DISCOM, Applicant and Channel Partners, System integrators etc. at a single platform. So that it is easier for applicant to gather all the required information from one single source and minimum manpower is required at the end of implementing agencies so as to reduce their administrative burden.

Hence is envisage to develop a new web application, designed and developed under a robust contracting arrangement on which OREDA will have the complete control. The web tool although being interactive will be firewalled with high end security layers to enable the security of the information from applicants. The proposed web application will cover the entire application process from applicant registration to release of subsidy disbursement letter. However, considering with the safety and security issues involved in online payment, disbursement of subsidy shall not be through the proposed web tool.

Thus, in order to make the new web application up and running at OREDA’s end, following are the requirements:

- New domain name on which portal will be hosted (WWW.xyz.com)
- SSL certificate for the domain name (recommend)
- OS Windows 2012 R2
- IIS with .net framework 4.5 and above
- DB: MS SQL Server 2012
- MS SQL Server Reporting services
- Space : 100GB(depend on volume of data)
- Accessibility to servers for the hosting the applications and Database

Once the web application will be active, the process map for Implementation of the RTS shall be as follows.

**1. Process for availing subsidy (for captive RTS projects)**

In this process applicant will fill the information relevant for subsidy only. OREDA will receive the application form in MNRE prescribed subsidy form (FORM-B or C). On receiving the application form OREDA will screen the form and will issue a subsidy sanction letter to applicant. On receiving the subsidy sanction letter, applicant will go for project installation and will upload copy of work completion report on web portal. On receiving the work completion report OREDA will come for inspection and will release the subsidy if the result of inspection is satisfactory. The overall processing time in the complete process will take 70 days from zero date, including project installation time of 50 days and administrative approvals of 20 days

**2. Process for availing connectivity (for Net Metering based RTS system without subsidy)**

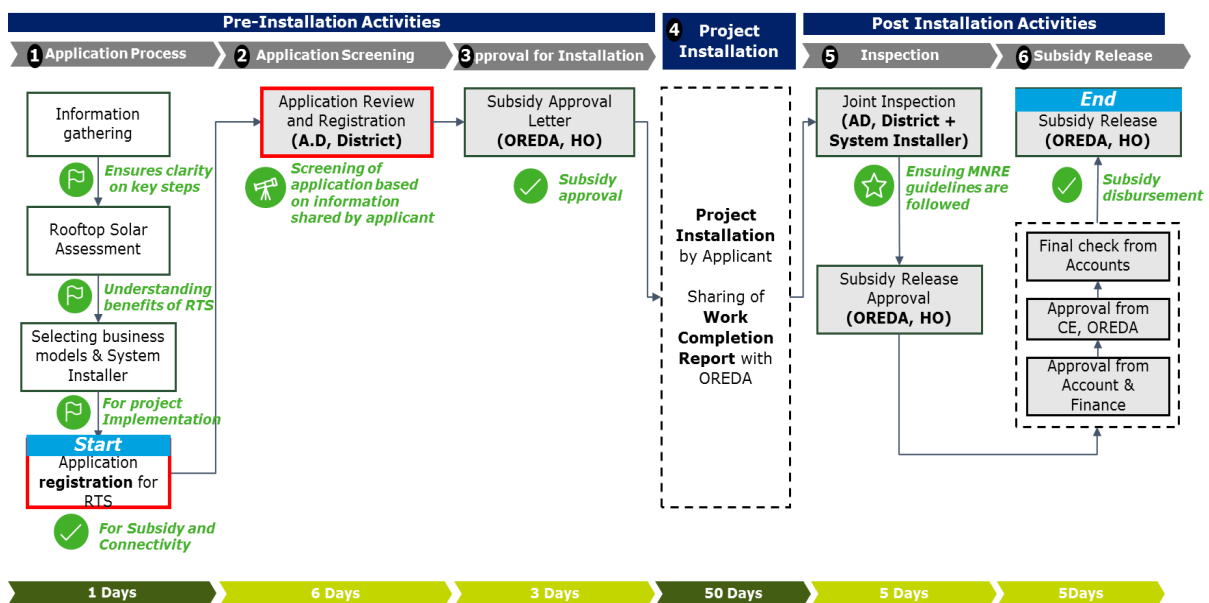

In this process applicant is seeking for connectivity only, hence it will fill the information relevant for connectivity in the application form. DISCOM will receive the information in their prescribed application forms. On receiving the application form DISCOM will screen the application form and will sign interconnection agreement with the applicant. After this, DISCOM officers will conduct interconnection feasibility. If the project is found feasible for interconnection DISCOM will issue NOC (No objection certificate) for net metering to applicant. On receiving the NOC, applicant will go for project installation and will upload copy of work completion report on web portal. On receiving the work completion report DISCOM officers will come for installation of net meter and commissioning of the project. On commissioning, DISCOM will issues a commissioning certificate to applicant. This complete process will take 68 days including 50 days for project installation and 18 days for administrative approvals.

### 3. Process for availing both subsidy and connectivity (for Net Metering based RTS with subsidy)

In this process applicant is seeking both connectivity and subsidy. Hence the applicant will fill the complete form which will include details regarding connectivity and MNRE Subsidy. On submission of application, DISCOM

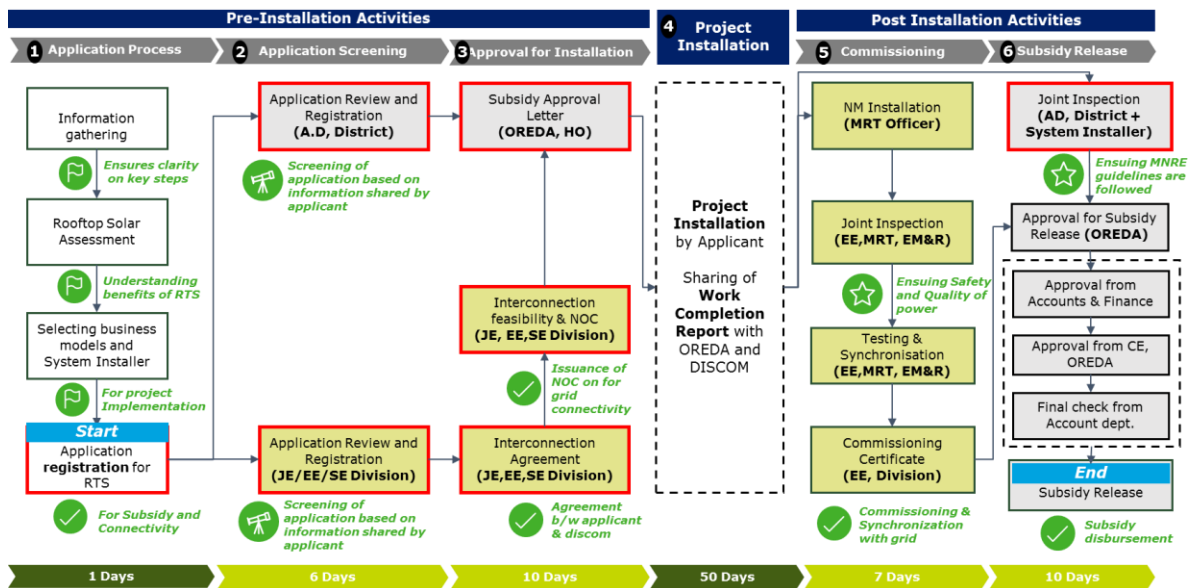

will receive information in their prescribed format and OREDA will receive as per MNRE subsidy form. On receiving the application form DISCOM will screen application and will sign interconnection agreement. Post this, DISCOM will conduct interconnection feasibility and issues a NOC for net metering. While OREDA on receiving the application will go for application screening and will issue a subsidy sanction letter on ensuring the connectivity approval from DISCOM.

Applicant on receiving approval from both the agencies (OREDA and DISCOM) will install the project and will upload the work completion report on web portal. On receiving the work completion report DISCOM officers will come for inspection and commissioning of project, on commissioning of project DISCOM will issue a commissioning certificate to applicant. While OREDA on receiving the work completion report will come for site inspection to ensure the compliance of MNRE subsidy guidelines and will sign joint inspection report with applicant and system installer. After this, OREDA will ensure the commissioning of project and on getting the commissioning certificate it will initiate the process of releasing the subsidy

Proposed timelines for execution of the whole process through web application is 85 days including project installation time of 50 days and administrative approval of 35 days.

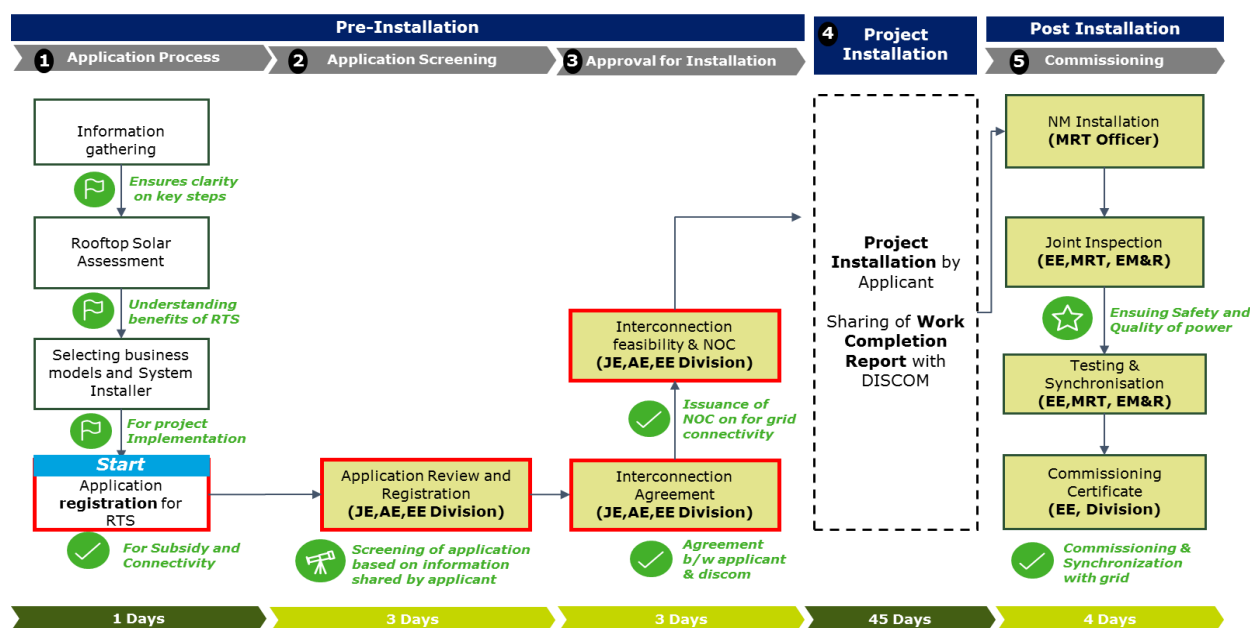

Timelines taken in each activity are follows

Phase	Activity	Subsidy (1)	Connectivity (2)	Both (3)*
<b>1. Application Process</b>	1. Application to OREDA	1	*	1
	2. Application to DISCOM	*	1	
<b>2. Application Screening</b>	1. Application Screening at OREDA	6	*	6
	2. Application Screening at DISCOM	*	3	
<b>3. Installation Approval</b>	1. Signing of Interconnection Agreement by DISCOM	*	7	10
	2. Interconnection Feasibility Check by DISCOM	*		
	3. Issuance of NOC by DISCOM	*		
	4. Issuance of Subsidy Sanction Letter	3	*	
<b>4. Project Installation</b>	1. Installation of RTS Project by Applicant		50	
<b>5. Site Inspection</b>	1. Installation of Net Meter	*	7	7
	2. Inspection by DISCOM	*		
	2. Testing and Commissioning	*		
<b>6. Subsidy Release</b>	3. Issuance of Commissioning Certificate	*		
	1. Inspection by OREDA	5	*	10
	2. Subsidy Release by OREDA	5	*	
<b>Total Processing time from Zero Date</b>		<b>70</b>	<b>68</b>	<b>85</b>
<b>Processing time for Administrative Approvals</b>		<b>20</b>	<b>18</b>	<b>35</b>

## 2 Background

With energy security and climate change concerns taking center stage in the policy arena, Renewable Energy (RE) has become an important part of the agenda in India's energy planning process. To this effect the government has set aggressive renewable energy targets and has put in place several policy initiatives at the Central and State levels for both grid connected & off-grid renewable energy.

Solar energy is fast becoming the preferred option in the development of renewable energy resources in the country. With about 250–300 sunny days in a year, around 5,000 trillion kWh of energy is incident on an annual basis over India's land area, with most parts receiving 4-7 kWh per sq. m per day. A study carried out by the National Institute of Solar Energy (NISE) estimated that India has a potential of 748.9 GW of solar capacity including both ground mounted and rooftop solar projects.

To tap the solar potential in the country, India had embarked on an ambitious program under the Jawaharlal Nehru National Solar Mission (JNNSM) in 2009, targeting to achieve an installed capacity of 20,000 MW of solar power by 2022. However, realizing the vast potential and fast technology growth, this target has been revised in 2015 to 100 GW to be achieved by 2022. This target is proposed to be achieved through deployment of 40 GW of rooftop solar projects and 60 GW of large and utility scale projects.

Rooftop solar installations across the globe have been driven by incentives offered through various schemes leading to faster tariff parity with utility supply. These incentives have been in the form of direct capital subsidy, tax credits, net metering, solar specific purchase obligations etc. In India, various schemes have been launched to realize the full potential of rooftop solar projects. To support rooftop solar projects, a number of states are incentivizing rooftop solar systems through net metering regulations.

On similar lines, Government of Odisha (GoO) is also earnestly exploring different sources of clean energy, to meet its increasing energy requirement, diversify sources of energy and address potential climate change issues. With about 280 - 300 days of sunshine a year and a Global Horizontal Solar Irradiance average of about 4.5-5.0 KWh/m<sup>2</sup>/day, Odisha has fairly good potential for solar power generation.

In addition, based on the Renewable Purchase Obligations (RPO) specified by the Odisha Electricity Regulatory Commission (OERC) which mandates large electricity consumers to procure power from renewables. The Odisha Renewable Energy Policy, 2016 sets a target of 2,200 MW of additional solar generation by 2022; this includes generation through roof-top solar and other non-land based solar projects. The Government has taken several initiatives for the promotion of rooftop solar projects in the state and is also supporting Central Government schemes for the development of rooftop solar segment.

The Odisha Renewable Energy Development Agency (OREDA) is the State Nodal Agency for promotion of renewable energy and aims to enhance the proliferation of rooftop solar within the State for projects less than 1 MW. OREDA as the State Nodal Agency (SNA) is also responsible for supporting the Central Government schemes for proliferation of solar rooftops. It has undertaken several measures and plans to assist the consumers and Utilities in Odisha for large scale implementation of rooftop solar program.

### 2.1 Objective of Assignment

Govt. of Odisha has recently taken up a city wide rooftop program on Govt. building as a pilot project to show case the benefits of solar rooftops. After the successful implementation of this program, Govt. of Odisha wants to take it further to other consumers belongs to domestic commercial and industrial class. However, to achieve ambitious targets, it is necessary that all the key stakeholders such as State nodal agencies distribution utilities, consumers, solar system installers, Regulatory Commissions etc. work together and create the ecosystem for development of solar rooftop projects in the country.

Hence with this objective, this assignment envisage to develop institutional capabilities within OREDA and other state agencies for expanding the grid connected rooftop solar initiatives in the state. This would involve supporting OREDA in developing the processes, procedures and necessary infrastructure for extending the benefits available under various schemes to the end consumers and supporting them in the decision making and implementation process.

### 2.2 Scope of Work

As a part of this initiative, IFC is extending support to OREDA and has engaged Deloitte Touche Tohmatsu India LLP in conducting review of the existing process of rooftop solar proliferation, identify gaps, provide recommendations and assist in development of IT architecture and application/tool to support adoption of rooftop solar by consumers.

Broad Scope of the project is as follows;

1. **Phase 1:** As-Is Analysis of OREDA and process for rooftop solar projects
2. **Phase 2:** Standardization of the OREDA processes
3. **Phase 3:** Development, testing, implementation of the Static web tool/application

This report focuses on bringing clarity to the current process (**Phase-1**) of implementation of solar rooftop in Odisha, with an objective to conduct detailed gap assessment of the same and propose recommendations for developing best practices. Broad areas covered under this report are as follows.

- Policy framework prevailing in Odisha and at national level for the implementation of rooftop solar projects covering residential, institutional and industrial sectors.
- Central and state government schemes and programs applicable for the rooftop solar projects
- Existing institutional framework for setting up and operating rooftop solar projects in Odisha and availing the applicable benefits under specific policies/schemes.
- National and international rooftop solar experience to identify best practices that can be adopted in Odisha for large scale proliferation
- Standardization framework template for the processes to be followed at OREDA for the rooftop solar projects
- Undertake Gap analysis of the processes and procedures - Identify and describe existing issues and barriers in the existing processes and procedures

Further, this report also maps the project development steps, approvals and clearances, etc. taking into consideration the classification of installations: Residential, Commercial, Industrial, Public/Institutional Consumer category, etc. The overall objective of this report is to prepare a detailed as-is assessment report for OREDA identifying the key gaps in the overall process with clear detailing of the as-is process map. This shall include quantification of the timelines/duration with respect to standard process from existing national/international practices.

### 3 Introduction

Solar sector in India had a slow start post the launch of JNNSM, but the growth has picked up in a short span of time. The capacity has risen significantly in the last five years, reaching to ~9.5 GW (by Feb, 2017) from just 841 MW in 2012. Incentives programs like Generation Based Incentive (GBI), Viability Gap funding mechanism (VGF) and Capital subsidy program have provided significant financial incentive to invest in solar energy. Apart from JNNSM, almost all state governments have introduced solar specific state policies and have notified Feed-in-Tariffs to promote solar generation.

**Figure 4: Growth of Solar in Last five Years**

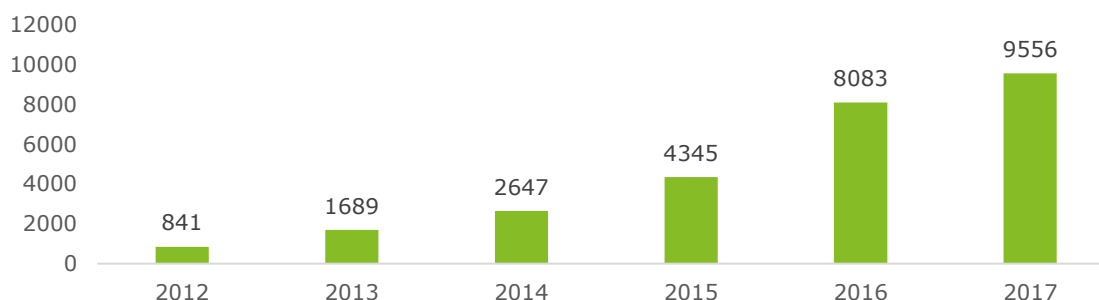

*Source: MNRE*

Further, with technology innovations and reducing module prices, solar PV tariffs are fast reaching grid parity. Since the launch of JNNSM in 2010, Solar PV capital costs and tariffs have decreased by approximately 65%, from Rs. 17 Crore per MW in 2010 to Rs. 6.06 Crore per MW in FY16. Considering continuous reducing cost trend of solar PV projects, CERC for FY 17-18 has moved away from determining capital cost/tariff for solar projects. With steep reduction in the solar costs and increase in generation tariffs from conventional fuels, small solar projects like solar rooftops are also becoming popular in India. Recognizing the importance of solar rooftops, several states have issued policies and developed regulatory framework for development of solar rooftops.

Solar rooftops has several benefits, the unutilized space on rooftops provides a large potential for generating solar power. Small quantities of power generated by each individual household, industrial building, commercial buildings or any other type of building can be used to fully / partially fulfil the requirement of the building occupants and surplus, if any, can be fed into the grid. Rooftop solar PV systems have the advantage of low installation time, providing clean and quiet source of energy. They can also improve the reliability of power supply for rooftop owners. Further, for state utilities it eliminate the need for developing long-distance transmission lines associated with large-scale solar generation plants and save on network losses associated with large-scale plants wheeling power to load centers.

#### 3.1 Policy and Programs for Solar Rooftop in India

Under the new ambitious target of 100 GW set under the JNNSM program, MNRE has allocated 40 GW for solar rooftops and is making concerted efforts to promote grid connected solar rooftop projects. However, promotion of solar rooftops/distributed generation has always been a focus area for Government of India. Further, so far more than 20 states have come out with Solar Policy supporting grid connected rooftop systems.

All major sectors i.e. Railways, Airports, Hospitals, Educational Institutions, Government Buildings of Central/State/PSUs are being targeted apart from private sector for development of solar rooftops. Ministry has also tied up with ISRO for Geo tagging of all the Rooftop plants using ISRO's VEDAS Portal. The graph below is presenting the roadmap of MNRE for achieving the 40 GW of rooftop target by 2022.

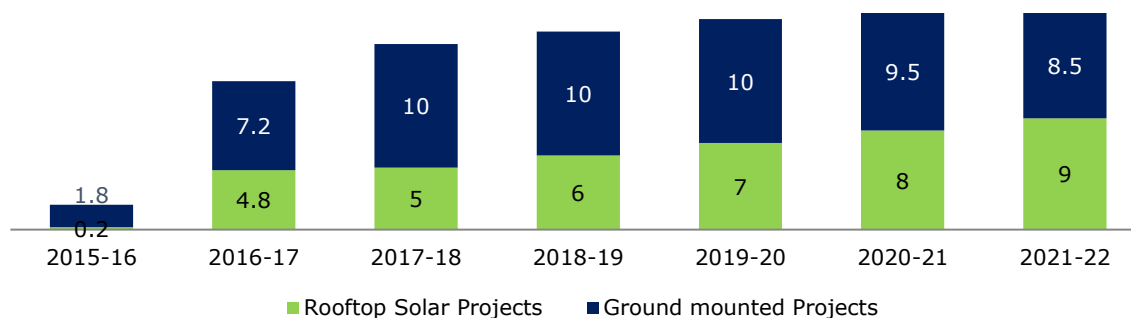
**Figure 5: Capacity additions under JNNSM (in GW)**

Source: MNRE

Some of the key schemes launched by MNRE in the recent past with focus on developing rooftop capacity in India are as follows;

1. **RPSSGP Scheme:** To promote solar rooftops in India, in July 2010 MNRE launched “Rooftop PV & Small Solar Power Generation Program” (RPSSGP)” scheme. This scheme was based on Generation-Based Incentives (GBI) to incentivize the installation of Rooftop PV and Small Solar Power Plants connected to the distribution network (at or below 33 kV level). A generation based incentive (GBI) was given to the utilities to cover the difference between the tariff determined by Central Electricity Regulatory Commission (CERC) and the base price of Rs.5.50 /kWh (FY 2010-11) with 3% escalation per annum. In all, 71 projects were commissioned across 12 states under the RPSSGP scheme with total installed capacity of 90.8 MW<sup>1</sup>. However, it was observed that this scheme garnered enthusiastic responses primarily in the ground-mounted segment, while it received almost negligible interest in the rooftop segment.
2. **Capital Subsidy Scheme:** MNRE also launched a national level ‘Grid Connected Rooftop and Small Solar Power Plants Program’ on June 2014 which provides Central Financial Assistance (CFA) of up to 30% of the capital cost for plants ranging from 1 kWp to 500 kWp in residential, commercial and institutional sectors. Later in November 2015, MNRE discontinued subsidy to commercial and industrial establishments in the private sector as they are also eligible for other benefits like accelerated depreciation, custom duty concession, exemption in excise duty, tax holidays etc. Further in 2016, MNRE also discontinued subsidy for government institutions including PSUs. Thus, remaining sectors including residential, institutional (hospitals, Educational Institutes etc.) social Sectors etc. are now only eligible to participate under the subsidy program.
3. **Allocation of target to State’s and PSUs:** Government institutions which have large space availability can play a pivotal role in achieving these targets. Such institutions have high power demand and rooftop space available can be utilized to meet their captive needs through a clean source. In addition, this shall also contribute towards achieving their CSR mandate.

To achieve 40 GW target, MNRE further allocated the targets to different states as per their energy demand and approached PSUs and other government institutions to invest in rooftop projects. Supporting the mandate, PSUs like NTPC, CIL have already taken steps towards investments. The figure below is presenting the targets allocated to different States by MNRE to achieve 40 GW rooftop capacity by 2022

<sup>1</sup> Ministry of New and Renewable Energy, Annual Report 2014-15

Figure 6: MNRE state-wise targets for Solar Rooftops

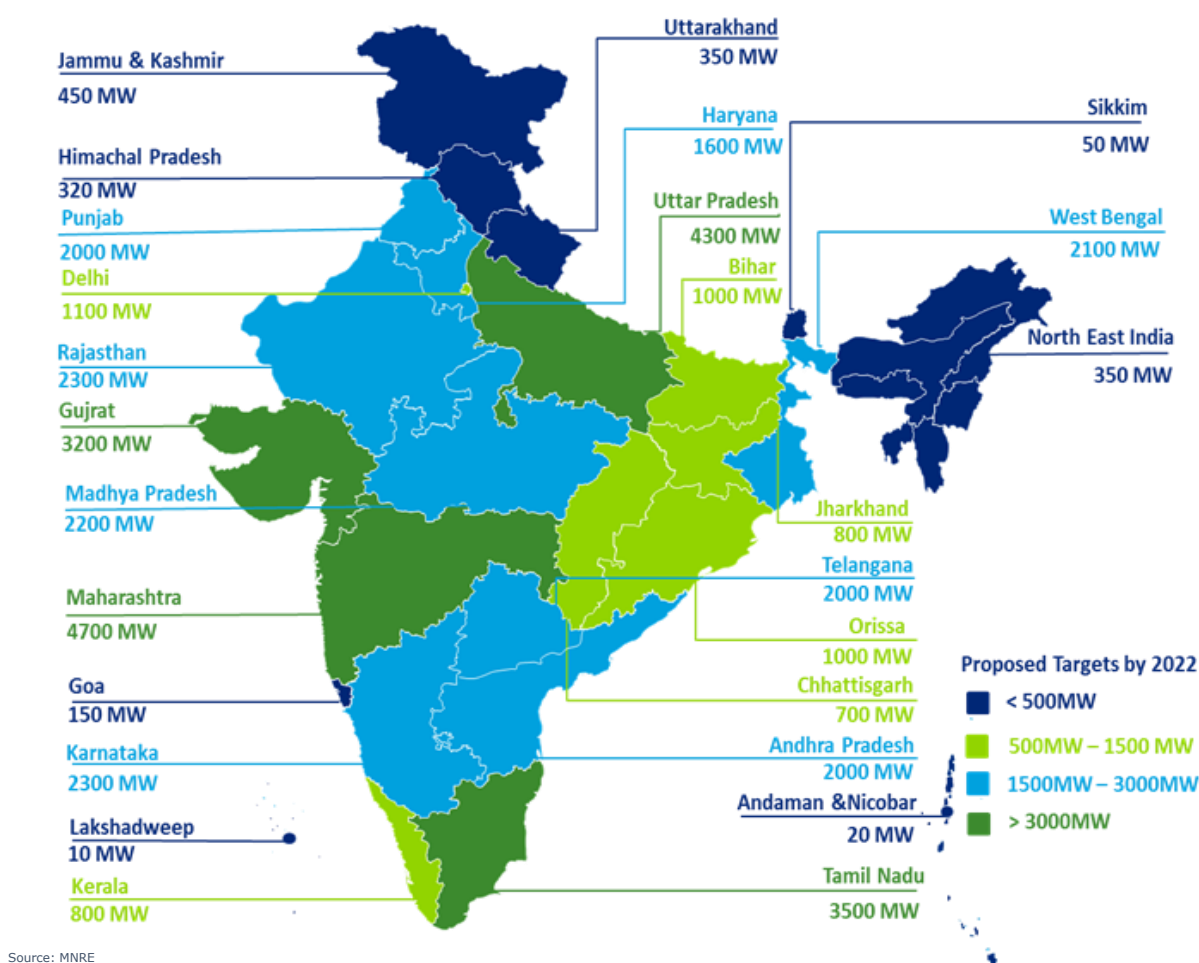

4. **Soft Loans through IREDA** – To facilitate consumers in arranging funds for development of solar rooftop projects, IREDA in July 2015 announced loan scheme for all Grid connected/interactive Solar PV projects located on rooftops. The scheme is applicable for Private Sector Companies/ firms, Central Public Sector Undertaking (CPSU), State Utilities/ Discom/ Transco/ Genco / Corporations and Joint Sector Companies willing to invest in project size of at-least 1000 kW.

Under the scheme, IREDA shall provide 70% of the project cost as a loan with minimum promoter's contribution of 30%. For fixing interest rate, IREDA will conduct credit rating of grid connected projects and provide grading in a band of 4 grades based on the risk assessment. The interest rates are linked with the grades. The interest rates are fixed by a Committee, the applicable interest rates are in the range from 9.9% to 10.75%. The maximum repayment period for the loan is up to 9 years, with the moratorium period of 12 months from the date of COD of the project. The maximum construction period shall be 12 months from first disbursement

5. **Soft loan for Rooftops as a part of Home loan** – To support end consumers in arranging funds for installing solar rooftops, In 2014-15, Ministry of Finance through notification have advised small commercial banks to encourage the home Loan / home improvement loan seekers to install Rooftop Solar PVs and include the cost of such equipment in their housing loan proposals just like non solar lighting, wiring and other such fittings. In response of the same, key commercial banks ( Syndicate Bank, Bank of India, Dena Bank, State bank of India, Punjab National Bank, Allahabad bank, Indian Bank, Central bank of India, Indian Overseas bank, State Bank of Bikaner and Jaipur, Bhartiya Mahila Bank) issued notice to their branches and issued guidelines for the same.
6. **Achievement Linked Incentive for Govt. Sectors:** Under the 40 GW solar rooftop target, GOI has allocates targets to each State. To achieve the targets in time bound manner, Govt. of India has recently

came out with a scheme to incentivize implementing agencies such as State government department, PSUs and other government organizations (SNA/ULBs) based on achievement of targets. The conditions for achievement linked incentives are as follows

S. No	Achievement vis-à-vis Target allocation	Incentives for General Category States/UTs	Incentives for Special Category States/UTs
1	80% and above within sanctioned period	Rs. 16,250/kW	Rs. 39,000/kW
2	Below 80% but above 49% within sanctioned period	Rs. 9,750/kW	Rs. 23,400/kW
3	Below 50% but above 39% within the sanctioned period	Rs. 6,500/kW	Rs. 15,600/kW
4	Below 39%	Nil	Nil

Source: MNRE

7. **Incentive Scheme for DISCOMs for expeditious development of Grid Connected Rooftop Solar Power Plants** - Discom play a key role in proliferation of solar rooftop as they provide approval for installation, provide electricity balancing services, manage the distribution network and also have billing interface with rooftop owner. As discom already have access to consumers, rooftop client acquisition or demand aggregation for them is easy. Moreover, discom already have organized invoicing/ billing/ execution systems, which is understood and accepted by all customers. Hence MNRE is incentivizing distribution utilities for implementation of solar rooftop in a fast manner.

As a part of this scheme, MNRE will provide performance enabling financial support to discom to accelerate deployment of rooftop systems within their distribution area. This Scheme would provide financial assistance in the form of grant up to maximum of Rs. 37.5 lakh per installed MW of RTS. Key objective of the scheme is to expand rooftop projects by supporting capacity of 1,350 MW in various sectors, and also to support the discom to assess upgradation and modernization requirements of their distribution network, facilitate demand aggregation, developing consumer awareness, developing enabling forms/ processes, meter/ equipment procurement, capacity development, etc.

### 3.2 Policy and Programs for Solar Rooftop in Odisha

National Institute of Solar Energy (NISE) has estimated a potential of 25.78 GW of solar power in Odisha. Realizing this potential, Government of India has allocated 1 GW of Rooftop target to Odisha under the 40 GW national target to be achieved by 2022. Figure below is indicating annual targets set by MNRE for solar rooftop for Odisha.

Figure 7: Solar Rooftop target of Odisha

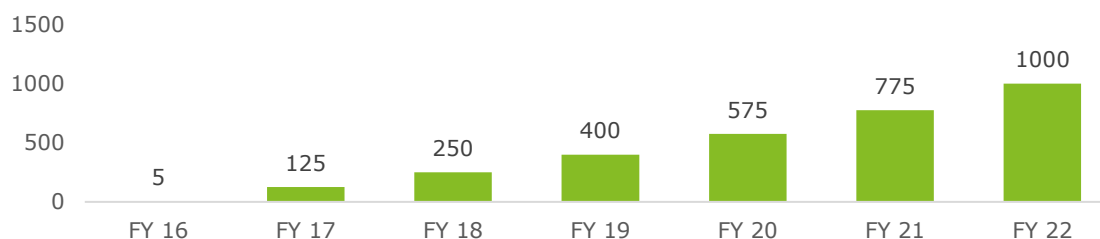

Source: MNRE

In view of achieving these targets, Govt. of Odisha has taken several initiatives through policy interventions, some of the key initiatives are as follows

1. **Odisha Solar Policy, 2013** - Odisha under the Odisha Solar Policy, 2013 identify solar rooftop as one of the focus areas for development of solar capacity in the State. The policy focuses on promotion of Grid Interactive roof top solar power projects with individual capacities ranging from 0.5 KW to 500KW

for different Government, semi Government and Non-Government institutes as well as private households with the objective of shaving day time peak power requirement, reducing AT&C loss and improve voltage. The targets set under the policy for solar rooftop are as follows

**Table 2: Rooftop Solar target under Solar Policy, 2013**

S. No	Year	Capacity (MW)
1	2013-14	2
2	2014-15	5
3	2015-16	10
4	2016-17	15
5	2017-18	20

The policy also directs Housing and Urban Development Department to take appropriate steps by change in city bye laws to facilitate the extensive use of solar roof top PV systems. Policy also suggest Urban Local Bodies (ULBs) in the state to adopt model bye laws as per the policy guidelines given below

**Table 3: Guidelines for Change in City Bye laws**

S. No	Segments	Deployment of Solar PV Plant
1	Individual households	0.5 kW with floor area more than 300 Sqm
2	Hotels	
2.1	Five Star and Above	10 kW
2.2	Other Hotels	5 kW
3	Commercial Buildings with floor area more than 5000 Sq.ft.	2 kW
4	Hospitals	As per requirements
5	Advertisement Hoardings	10% of all Hoardings by 2020 as per requirement of the respective hoardings
6	Mobile Towers	25% of all towers by 2020 as per requirement of the towers

*Source: Odisha Solar Policy, 2013*

2. **Odisha RE Policy- 2016:** Government of Odisha in 2016 came out with a new RE policy. Under the Renewable Energy policy, 2016 it also identified distributed generation as one of the focus areas. The policy aims at achieving 2,200 MW of solar power by 2022. The policy identifies OREDA as the nodal agency to execute and coordinate all distributed RE projects. The policy focuses on developing distributed renewable energy application through rooftop solar projects, RE based mini/micro grid, Solar water pumping, wind solar hybrid projects, solar thermal projects etc. however the policy is silent on the targets for individual applications.
3. **Solar City Program:** Ministry of New and Renewable energy (MNRE) has identified Bhubaneswar as one of the solar cities under the Solar City program announced by Govt. of India. As per the master plan approved by MNRE, promotion of renewable energy will be one of the focus area for Bhubaneswar city. Solar city master plan aims to achieve 230 MW of RE energy though consumption of 10% of total power from RE Sources. Under the plan, consumers will be promoted though suitable incentives to install suitable solar applications from the following
  1. Solar PV to generate electricity
  2. Solar Water Heaters
  3. Solar Lanterns for lighting
  4. Solar home lighting system
  5. Solar inverters

The Solar City plan envisage development of 1.8 MW of solar PV for residential apartments for saving of approximately 2.7 MU of energy and 2,187 tons of carbon emissions. The solar strategies prepared for residential sector would help in achieving 29% of the total target which is 157.01 MU of energy. Solar PV targets in other consumer category is as follows

**Table 4: Solar PV targets for different Consumer Categories**

S. No	Category	Target (MW)
1	Educational Institutes	1.031
2	Hospitals and Health Sector	0.109
3	Hotels	0.134
4	Restaurants	1.155
5	Temples	1.675
6	Commercial and institutional sector	0.871
7	Industrial Sector	37.116
8	Municipal Buildings	3.416

*Source: Bhubaneswar Solar City Master Plan*

4. **Odisha Smart City Program:** Bhubaneswar has also been identified as the smart city under the Govt. of India Smart City mission. The city is under the obligation of renewable energy interventions and energy conservation measures under the same. As per the smart city program, Bhubaneswar has a target of consuming 10% of total power through solar power, which translated to 10 MW. However there is no separate target for rooftop or ground mounted solar projects under the program.

### 3.3 Regulatory framework for Solar Rooftop in Odisha

Odisha Electricity Regulatory Commission (OERC) in **November 2014**, came out with an Order on Net Metering and its connectivity with respect to rooftop solar PV projects on the rooftop of Government / PSU owned buildings. Under the said order, OERC issued the guidelines for Net Metering based solar rooftop project in Odisha. Salient features of the Order are as follows;

1. The order allowed eligible consumers to install net metering based solar rooftop projects having maximum capacity equal to the sanctioned load of the consumer. It also allowed them to feed the excess power into the grid.
2. To maintain the safety and security of the grid, the OERC set the cumulative capacity to be allowed for a particular distribution transformer **to not exceed 30%** of the capacity of the distribution transformer.
3. The OERC also allowed the distribution utility to fulfill their RPO target from the energy consumed by the net metered consumers from solar rooftop.
4. The OERC also mandated the project above 20 kW to install two meters i.e. solar and net meter. Solar Meter to record the solar generation and Net Meter to record the net consumption by the consumer.
5. For energy accounting, electricity generated from a solar rooftop PV project is capped cumulatively at 90% of the electricity consumption by the consumer at the end of a settlement period. Excess generation in any billing cycle is allowed to carry forward to next month billing cycle as energy credits.
6. In case on Net Import, consumer will have to pay for net consumption based on the supply tariff. In case on net export, excess generation in any billing cycle is allowed to carry forward to next month billing cycle as energy credits.

**Later in May 2015**, OERC came with first amendment in the Order and allowed all other building to set up solar rooftop projects in addition to Govt. PSUs. Further it also clarified that sale to 3<sup>rd</sup> party of the power generated from the Rooftop Solar PV is not permitted. The banking of electricity from solar rooftop project is also not allowed by the OERC.

**In August, 2016**, OERC further amended the guidelines and allowed all distributed projects either ground mounted, roof mounted, elevated structure, or for captive use to be considered as rooftop project. **It also extended the cumulative capacity to be connected to DT from 30% to 75% of the transformer capacity.** Further, it also removed the restriction on project capacity as long as it is within sanctioned/contracted load. Earlier it was 1 MW. OERC under the same order also listed out all the rules and regulations to be referred while installing solar rooftop project and connecting it to the grid.

## 4 Process for Implementation of Rooftop Solar in Odisha

For development of power sector in Odisha, Govt. of Odisha has clearly outlined the roles and responsibilities of all agencies involved in the State. State has fleet of generating stations from central to state owned and from semi government to completely private projects. The responsibility of purchasing power from these generating stations and selling it to discom is with GRIDCO, an undertaking of Govt. of Odisha as trading company. OPTCL does the work of developing and taking care of transmission infrastructure connecting these generating stations to distribution utilities. State has four discom which connects the end consumers with utility grid and serve the purpose of electricity service provider.

State also has OREDA/GEDCOL as the execution bodies of Govt. of Odisha for development of renewable energy and energy efficiency. GEDCOL is involved in development of large scale grid connected projects and OREDA has the responsibility of pushing small de-centralized distributed generation in the State.

The institutional structure of Odisha for power is illustrated below.

**Figure 8: Institutional Structure of Power Sector in Odisha**

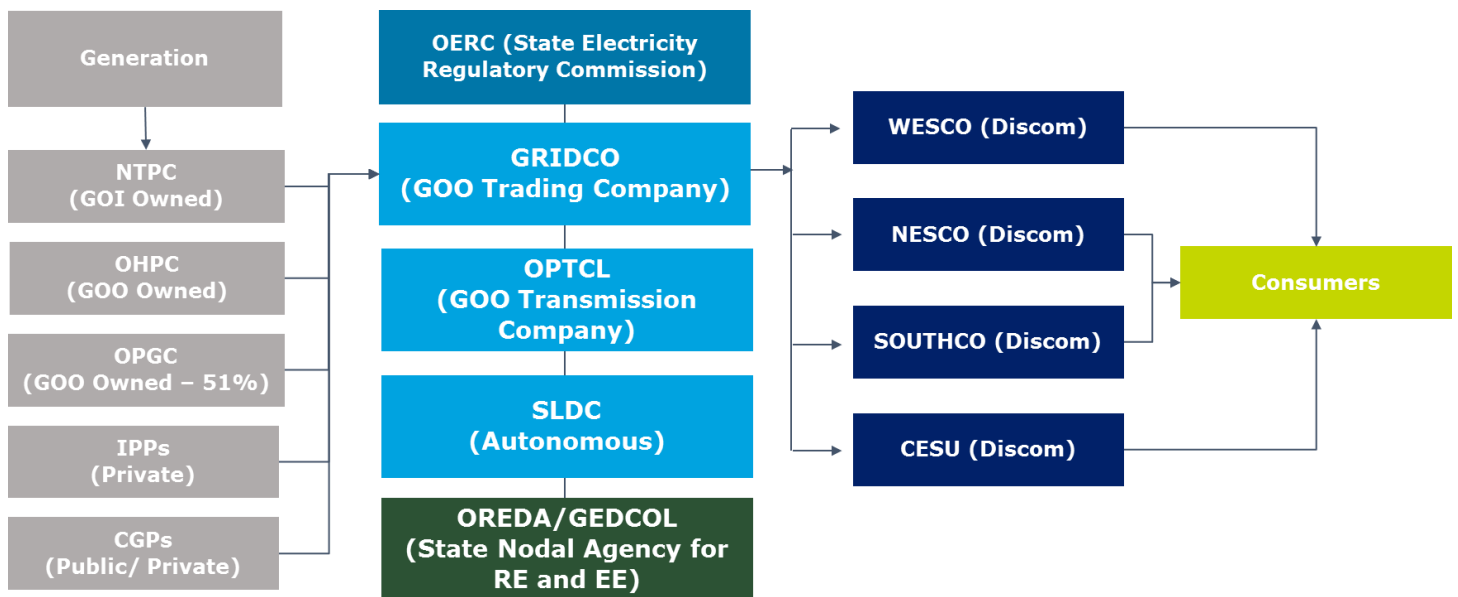

### 4.1 Key Stakeholders

As described above, there are several stakeholders involved in development of power sector, however for solar power the key stakeholders in Odisha are GEDCOL (Green Energy Development Corporation of Odisha) for development of utility scale solar projects, OREDA (Odisha Renewable Energy Development Agency) the state nodal agency for promotion and implementation of solar rooftop and distributed projects, OERC (Odisha Electricity Regulatory Commission) for setting rules and regulation and DISCOMs for connectivity and commercial settlement. Below figure is illustrating key Stakeholders involved in development of solar rooftop in Odisha with their role and responsibilities.

- 1. Odisha Renewable Energy Development Agency (OREDA)** – OREDA is the state nodal agency is under aegis of Dept. of Science and Technology. Govt. of Odisha aims to popularize use of renewable energy resources in the State. With a vision of 10% renewable energy share in total power mix of Odisha, OREDA plays a key role in proliferation of renewable energy in the State. It is responsible for development of solar power (distributed) through issuance of policy framework, monitoring and tracking the progress of RPO, providing capital support/incentive to end consumers, Consumer awareness etc.

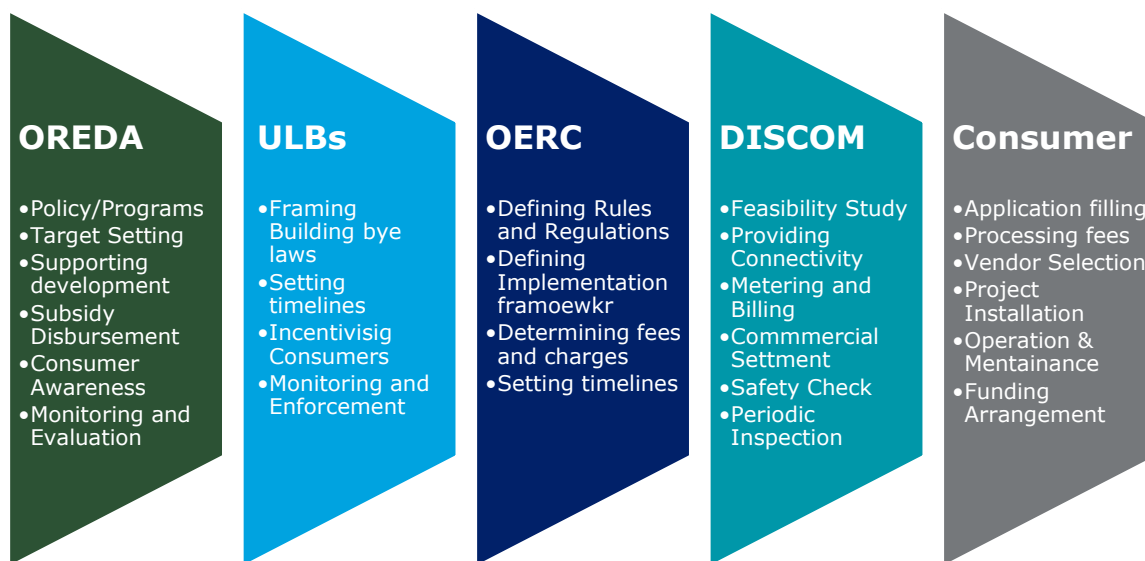
**Figure 9: key Stakeholder in Odisha for Rooftop Implementation**

- 2. Urban Local Bodies (BMC/BDA)** – Urban local bodies have the responsibility of urban planning, framing regulations of land-use and construction of buildings, planning for economic and social development, ensuring services like Public health, sanitation conservancy and solid waste management etc. As a part of urban planning and ensuring public health, reducing carbon emission and promoting renewable energy is also a focus area of ULBs. Under the building bye laws, regulation of land-use etc. ULBs have the authority to mandate consumers for installing RE projects and provide incentives (if required) to encourage more participation.
- 3. Odisha Electricity Regulatory Commission (OERC)** – OERC plays the role of state electricity regulator, by laying rules and framing regulations in line with the Electricity Act, 2003. With regards to solar rooftop, the role of OERC is to provide clarity on implementation framework, metering mechanism, Commercial settlement, technical limitations, safety standards, fees and charges, timelines etc. through Regulations/Orders. OERC sets the framework which is to be followed by other key stakeholders for implementation of solar rooftop in Odisha.
- 4. Distribution Utility (DISCOM)** – DISCOMs play an important role, as the rooftop system to be implemented and is to be connected with distribution grid. So the role of distribution utilities are to provide connectivity of solar rooftop system with the utility grid and to carrying out metering/billing activities post installation. During the process of installation, DISCOMs also plays a crucial role though site inspection, safety approvals, synchronization/commissioning approvals etc. The role of DISCOM becomes more crucial as it is directly interacting with consumers. Hence DISCOM also has to ensure connectivity with consumer through proper communication channels.
- 5. Applicant/ End Consumer** – Applicant/ End consumer comes towards the end of process chain, as it uses the energy generated from solar rooftop. The role of applicant is also very crucial, it has to ensure the feasibility of rooftop system based on its consumption and availability of roof space. Consumer must also be aware about the key business models, application process, applicable incentive/CFA from State or Central government, cost economics, competent vendors etc. Consumer must also be conversant with operations and periodic maintenance of solar rooftop project.
- 6. Renewable Energy Service Companies (RESCO)** – RESCOs are RE service providers which support end consumers in installation of solar rooftop projects through knowledge transfer, installation support, project procurement support, technical expertise, service provider etc. Role of RESCOs varies based on the business model chosen by the end consumer. It could be as project developer or as an IPP selling power to end consumers. RESCOs are also very important for proliferation of solar rooftop, as it provides the missing link between the technology and end consumer.

## 4.2 Broad Phases for Implementation of solar rooftop

Implementation of solar rooftop involves multiple steps such as collating information for project installation, checking financial viability, applying for subsidy, technical feasibility of rooftop, selection of appropriate vendor, project installation, getting grid connectivity etc. For ease of understanding, the whole process of project implementation is divided under broad phases. These phases includes all the steps involved in project lifecycle from the stage of concept till the commission of project. Figure below illustrates these broad steps

**Figure 10: Broad Phases for Implementation of Solar Rooftop**

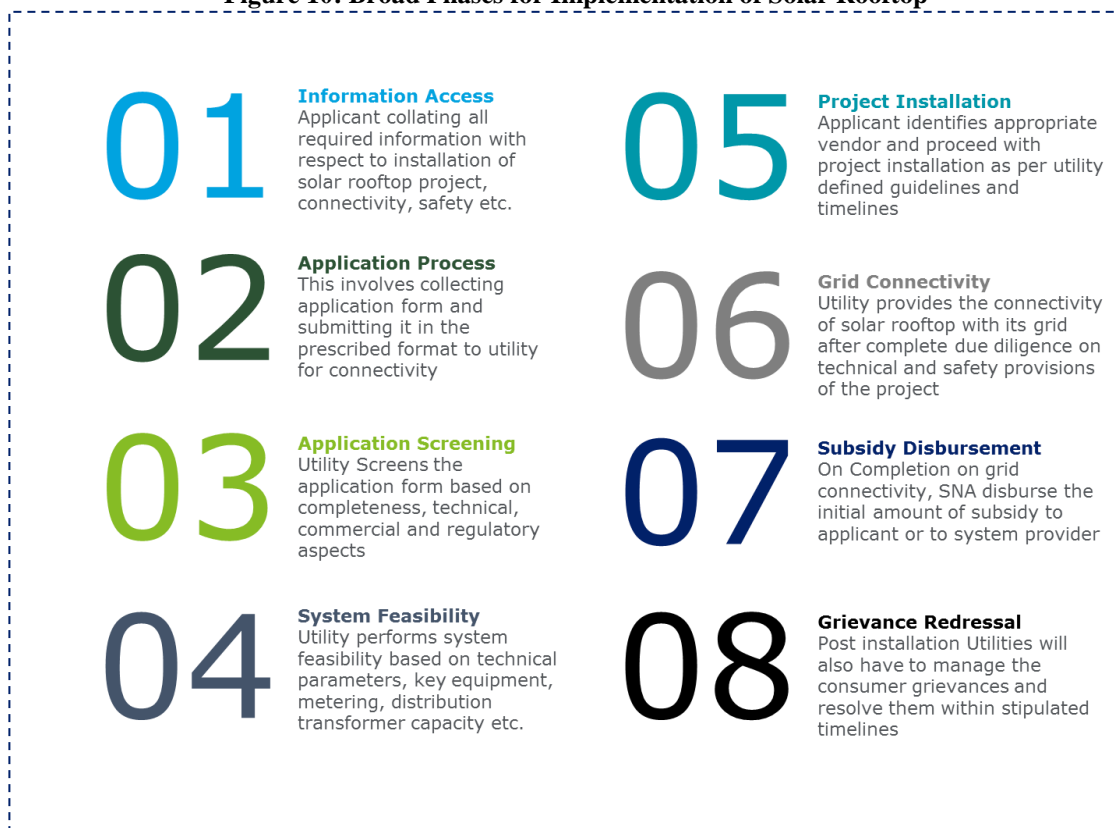

To map the current process followed in Odisha for the implementation of solar rooftop, the whole process is divided under these key phases.

### 4.2.1 Information Access

In this phase applicant collates all the required information with respect to solar rooftop and has to evaluate all possible business models before actual implementation of solar rooftop. In this area, the role of the implementing agency is to educate applicant on all the aspects of project planning.

Planning of solar rooftop project is generally executed with an objective to evaluate the cost benefit analysis of solar rooftop project. It involves several steps including sizing or project, estimation of annual yield, procurement, DPR preparation etc. Broad steps involved in planning of solar rooftop are illustrated in below figure;

**Figure 11: Project Planning Phases**

1. Policy and Regulatory Review

2. Project Sizing

3. Resource Assessment

4. Estimation of Annual Yield

5. Approval and Clearances

6. Key Equipments

7. Project Procurement

8. Feasibility Report

9. Project Scheduling

10. Project Financing

1. **Phase-1: Policy and Regulatory Review-** First step of project planning is the review of policy and regulatory framework for solar rooftop in the State. This helps applicant in getting the understanding of eligibility criteria, applicable charges, metering and settlement process, incentives/CFA support etc.

2. **Phase-2: Sizing of Project** – Second step it to carry out the sizing of project on the basis of availability of space and the energy consumption of the applicant. For simplicity, there are many service providers, for example ezyolare (<https://www.ezyolare.com/>) which help applicants in sizing of project, identifying vendors, cost economics etc. though online web-portal.

3. **Phase-3: Resource Assessment:** Resource assessment is a crucial part of project planning as this will help in estimation of annual yield of the project. This in turn will be used for computation of cost benefit analysis of the project.

For resource assessment, applicant can download satellite based data from NREL, NASA which is available free of cost online. For more accurate results, applicant can also collate paid data from METEONORM, 3TIER, Solar GIS etc.

4. **Phase-4: Estimation of Annual Yield:** Estimation of annual yield is computed based on the resources assessment of particular site. This helps in estimation of energy value for consumers. For ease, applicant can also refer web applications available online to download the data such as PV watt for free of cost.

For sample, the annual solar yield and the cost of energy value for 1 kW of domestic rooftop system with average supply bill of Rs. 4.31/kWh at Bhubaneswar downloaded from PV watt is given below;

**Figure 12: Estimation of Energy Yield and Energy Value in Bhubaneswar**

Months	Solar Radiations (kWh/m <sup>2</sup> /Day)	AC Energy (kWh)	Energy Value (Rs.)
January	3.95	92	398
February	5.37	110	473
March	6.48	140	603
April	6.85	139	598
May	6.36	131	566
June	5.37	112	483
July	4.87	109	471
August	5.28	120	516
September	5.13	112	483
October	5.67	126	544
November	4.61	102	440
December	3.96	95	408
Annual	5.33	1,388	5,983

Source: NREL, PV Watt

5. **Phase-5: Approval and Clearances-** For installation of solar rooftop system, applicant also needs to take approval from the following authorities
- Approval from SNA – for Sanction of Subsidy
  - Approval from MNRE – for exemption of custom and excise duty
  - Approval from Discom – For grid connectivity
  - Approval from Electrical Inspector – for project size above 50 kW
  - Approval of Structural Engineer – to assess the strength of building
  - Approval from Municipal Corporation – If there is change in building plan
  - Approval from Roof Owner – for third party model (lease agreement)

6. **Phase-6: Key Equipment's** – Applicant should also know the list of key equipment's used for installation of solar rooftop projects. In addition, applicant should also be aware about standards and specifications defined by CEA, OERC, and State Discom etc. for connectivity with the grid. Key equipment used for installation of solar rooftop are as follows.
- a. Solar PV Modules
  - b. Mounting Structure
  - c. Solar PV inverter
  - d. Solar and Net Meter
  - e. Array Fuse, Surge Protections
  - f. DC Combiner Box
  - g. DC and AC Distribution Box
  - h. Electric Cables
  - i. Junction boxes
7. **Phase-7: Project Procurement** – This process involves procurement of key components and selection of competent vendor for installation of rooftop project. During project procurement, applicant should also be aware about the cost economics of project as per existing market standards.

**Figure 13: Typical Project Costing of Solar Rooftop Project (Without Storage)**

S. No	Parameters	Cost (Rs./ Wp)
1.	Solar PV Module	27 - 30
2.	Inverter	10 - 12
3.	Mounting Structure	06 - 08
4.	Junction Box	0.5- 01
5.	Lightning Arrestor	0.5
6.	Earthing Strip	01
7.	Civil & Electrical work	09 -10
8.	Cables and Wires	1.5 - 02
9.	Engineering and Designing	03 -04
10.	Transportation Cost	0.5
11.	Other miscellaneous cost	01
<b>12.</b>	<b>Total Cost</b>	<b>60-70</b>

*Source: Secondary Research*

8. **Phase-8: Feasibility Report** – Preparation of feasibility report is a key step in view of availing subsidy or project financing. Feasibility report includes all the details of the project such as project sizing, resource assessment, key components, project costing, project feasibility etc. for project reviewer. The format of feasibility report is pre-defined by the implementing agencies like MNRE Form B and Form C for availing subsidy.
9. **Phase-9: Project Scheduling** – Project Scheduling describes the tentative timelines for different phases of project installation. This helps the consumer in estimation of project cost and time over run.
10. **Phase-10: Project Financing** – Project financing is a crucial step of project planning, this ensures the availability of fund for procurement and installation of project in a timely manner. For financing of rooftop project with commercial banks, consumer needs to provide detailed project report, Bill of Quantity, Company/Individual Financial credentials, credentials of system installers etc.

As a best practice, Project planning phases discussed above should necessarily be a part of information Access. So that the required information is readily available with Consumer. In the existing framework, OREDA Customer Relationship Center (CRC) platform provides required information to interested consumers/applicants for installation of solar rooftops in Odisha. Consumers can reach out to OREDA CRC through web portal (<http://www.odisharenewable.in/>) or helpline numbers to acquire relevant information on solar rooftop. OREDA CRC facilitates consumers in providing following information to consumers

1. Information on Solar Rooftop System
2. Key Components of Rooftop system

3. Subsidy/CFA (%) for installation of solar rooftop
4. List of frequently asked Questions
5. Pre-requisite's for installing Rooftop System
6. Rooftop Calculator/ Application Submission Platform
7. Application form (for offline submission)
8. Regulatory provisions for Installing solar rooftop
9. List of Empaneled Vendors by OREDA
10. Grievance Redressal Mechanism

In addition to OREDA CRC, Consumers can also reach out discom's Head Office/Divisional Office to get the relevant information and forms/formats required for installation of solar rooftop projects in Odisha.

#### 4.2.2 Application Process

Application process is the second phase of rooftop implementation process. It is another critical task for applicant and implementing agencies with respect to ease of procurement and submission of application form. Application process is also important for implementing agencies as it generally involves manpower and cost associated to it. By adopting best practices, implementing agencies can improve process to access, complete and submit the application form for applicants. Simplifying this task helps implementing agencies through reduction of administration burden and it will also help them to encouraging more applicants to adopt solar rooftops. Application process involves two broad processes; Application Access and Submission of Application form

**Figure 14: Application Process**



1. **Application Access:** Access to application forms and other relevant document is an extremely critical part of the process. Access to informative documents should be designed in such a way that implementing agencies can improve its operational efficiency. The objective of this process is to simplify the process by which an applicant gets relevant forms/formats and other relevant information with regards to approved vendors, standards and specification of key equipment etc. so as to reduce the overall time taken in collating and providing information.

The common and best practice in this area is to upload the relevant forms/formats, Agreements etc. on the web portal of implementing agencies. In addition to this, implementing agencies could also make information available to applicants through registered e-mails, billing outlets, utilities office etc. Some example of implementing agencies using web portals to spread out information to their consumers is MSEDCL (Maharashtra State Electricity Distribution Co. Ltd.), BESCOM (Bangalore Electricity Supply Company Ltd.), BSES Rajdhani Power Ltd. and BSES Yamuna Power Ltd. (Tamil Nadu energy development agency (TEDA), Punjab energy development agency (PEDA) etc.

2. **Application Submission** – Similar to accessing application forms, submission of application form is also one an important parts of the application process for both consumer and implementing agencies. The best practice in this area is to submit/collect the application form through multiple channels; ideally an efficient and streamlined application process allows submission of application forms and other supporting documents through online or e-mail to authorized utility personal. With online submission of application forms, implementing agencies can benefit themselves with reduction of time taken in preliminary screening in terms of completeness and correctness of applications and the complete application process can be completed in one day. This shall also help utility in shortening the whole application process by easily one or two days.

Submission process can be made more streamlined by categorizing the online submission in terms of consumer category, project capacity, location details etc. This process is not new for utilities in India as most of the utilities follows the same methodology for providing online billing facility to its consumers depending upon these details. Further, categorizing submission process in terms of project capacity or consumer category is also important as the interconnection process for different consumer category could be different. MNRE also provide subsidy support based on consumer category.

To further streamline the process, implementing agencies can also attach net metering application form with form for getting new electricity connection. So that with electricity connection, its net metering application also gets pre-approved and consumer doesn't have to seek approval at later stages. This practice can reduce a significant administration burden and time required for processing of interconnection application at later stages. In this process, implementing agencies can perform pre-feasibility check of rooftop system based on building plan, capacity of service line, contract load, existing load, DT capacity etc.

As per the existing framework in Odisha, application process involves processing of application at OREDA and concerned distribution utility. If the consumer is eligible for subsidy from MNRE and intends to apply for the same, it needs to submit the application to OREDA. Else the application is to be send directly to the concerned discom.

Based on the application sent to OREDA or DISCOM, these agencies process the application accordingly. Application process of OREDA or Discom is detailed below.

#### A. Application Process of OREDA

Once the applicant opts to avail subsidy, it needs to file the application form to OREDA. Application form can be downloaded from Odisha Renewable Energy Development Agency Customer Relationship Center (OREDA CERC) or from OREDA head office. The pre-requisite condition for application filling at OREDA CRC is that the applicant should be an existing consumer of State discom and it has following information.

1. Dimensions of roof space of proposed site
2. Shadow free area
3. Available area for project installation
4. Capacity of rooftop project on proposed site
5. Name of Discom
6. Division Number
7. Customer Account Number with discom
8. Connected/Sanctioned Load
9. Maximum Approved Capacity
10. Tariff Category

Based on the above information, applicant register its application of OREDA CRC (<http://www.odisharenewable.in/schemes/>). On registration, applicant gets confirmation notice from OREDA on its registered email ID with list of all the empaneled vendors and steps to be followed for further processing of application. On successful registration of application, empaneled vendors also gets applicant details for communication.

Consumer can also opt to submit the application offline also by downloading the application from OREDA CRC and submitting it to OREDA head office.

Application received through OREDA CRC or through offline channel are directed to the technical officer under the supervision of Deputy Director, OREDA, who is the Nodal Officer. Application format for online and offline submission of application to OREDA and Confirmation notice are given under Annexure (8.2 and 8.3).

**Figure 15: Odisha Application Process**

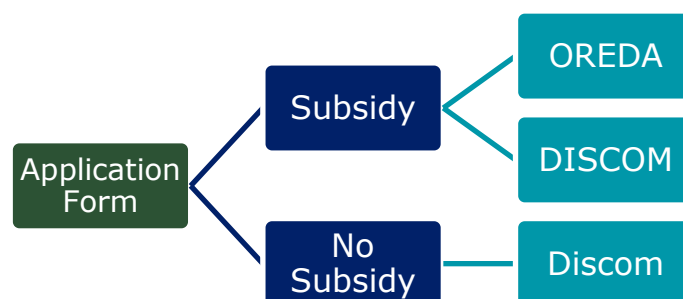

#### B. Application Process of Discom

Applicants which belong to commercial or industrial class, who is basically not eligible for subsidy are required to file application to discom. Applicants can reach out to discom's divisional office or corporate

office to get the required information and forms for installation of solar rooftop project. Applicants also have the option to download the application form through CESU's consumer portal.

Submission of application is also done through offline mode only. Along with the application form, applicant will also have to submit the receipt of application fees. Application fees is accepted offline by the divisional officer of discom. Other documents required to be submitted with the application forms are as follows

1. Copy of the latest Electricity bill (with payment receipt optional)
2. Authorization letter in case of Company/Trust/Co-operatives/ Partnership and for Partnership firms.
3. Copy of the Subsidy sanction letter from MNRE/ Self-certification for not obtaining MNRE subsidy (optional)
4. Single line schematic diagram of Solar Rooftop PV System (all available drawing)
5. All drawings and diagrams showing important equipment, protection and control features shall be signed by representative of the applicant
6. Self-certified Specifications of all solar project equipment's (Inverter, PV module, Cable, Junction boxes, protection systems etc.) and test certificate/reports of solar project equipment as per IEC/BIS standards.
7. Submission of safety aspects complied by the consumer with respect to Central Electricity Authority, Indian Electricity Grid Code, Odisha Grid Code, OERC Net Metering regulation and Discom's requirements (DC and AC earthing and surge protection details etc.)

On submission of application form along with all necessary documents, general screening will be done by the Division Office and application will be registered with acknowledgement to the applicant. Formats used for Application form and Fee Receipt is given under Annexures (8.4 and 8.5)

#### 4.2.3 Application Screening and System Feasibility

Once the application is submitted by the applicant, it is the responsibility of implementing agencies to review and process it within timelines. Improving efficiency in application screening and processing is a critical requirement of rooftop implementation process. Improvement in this area can help implementing agencies in reducing the soft costs incurred by it and the applicant during the whole interconnection process.

First stage of application screening is application review, wherein implementing agencies review the duly filled application forms as per general requirements for rooftop system such as applicant name, address, site location, project capacity etc. Once the application clears the general screening, it is processed for technical screening wherein the application is examined on the basis of technical parameters, interconnection study, system impact studies etc. Technical screening is generally performed by distribution utilities with an objective specifically check whether the proposed rooftop system is technically feasible and safe for the utility grid and connected load limits.

Best practice in this area is to track the processing time between the application submission and final screening of application by implementing utilities and try to reduce it. This will help both the applicant and implementing agencies to plan their resources in an effective manner and will reduce time and money for both the parties.

In Odisha, application screening happens at two places i.e. at OREDA and at Discom level. OREDA performs general screening of application process to check the feasibility of rooftop system for subsidy. While Discom performs both general and technical screening in view of system safety.

**Figure 16: Application Screening Process in Odisha**

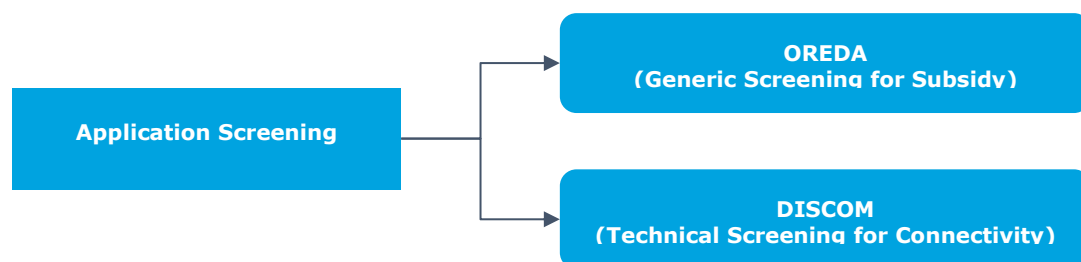

1. **Application Screening at OREDA:** On receiving the application form, OREDA goes for screening of application through detailed review of application forms. The objective of application screening is to check the correctness or completeness of application form and the eligibility of applicant for subsidy disbursement.

After general screening of application, OREDA officials goes for site inspection to check the roof size, shadow free area, proposed capacity etc.

Site inspection is conducted by Assistant Director (AD), OREDA of concerned district. Post inspection the report is sent to OREDA head office to the Nodal person. Nodal person at OREDA intimates the result of site inspection to respective applicant through e-mail. Figure below is illustrating the application screening process of OREDA

**Figure 17: Application Screening at OREDA**

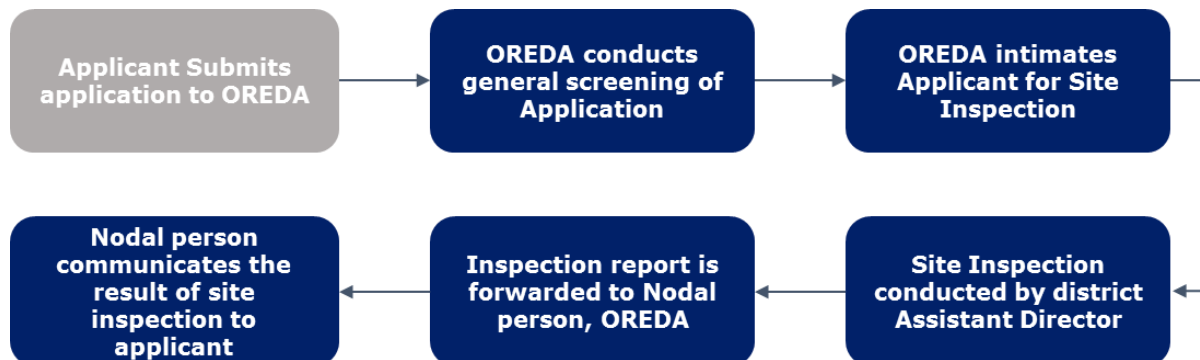

2. **Application Screening at DISCOM:** Discom on receiving the application goes for general screening in terms of application completeness and correctness. After this it undertakes a detailed feasibility check at proposed site. The objective of the feasibility check is to assess the proposed rooftop project based on parameters outlined below

1. Type of Applicant
2. Type of Connection (1Ph LT or 3 Ph LT/HT)
3. Metering Details
4. Contracted Load
5. Distribution transformer details
  - a. Location
  - b. Total Connected load
  - c. Rooftop Systems already Connected
  - d. Available Capacity of DT
6. Feeder Details
7. Rooftop System details etc.

The Divisional Manager along with E&MR and MRT Officers conducts the joint verification study on the technical feasibility and metering arrangement of the proposed rooftop system within 7 days from the date of submission of application. The technical feasibility report is then forwarded to discom Head Office for issuance of permission for Net Metering.

By this step, discom officials have broad information for system feasibility, technical feasibility, Solar rooftop system to be installed. For this, divisional manager waits for project installation. Once the project is installed, discom complete the feasibility including the system specification, standards, safety checks etc. and forward the report to discom head office for further processing. The format used for assessing feasibility of Rooftop System is provided in Chapter-8 (8.9)

On scrutiny of technical feasibility report, Discom Head Office gives permission to divisional manager for issuance of permission (NOC) for Net Metering to the applicant, if it is found technically feasible. Otherwise, the deficiencies are intimated to the division officers for further communication to the applicant for the necessary compliance. Format of NOC is provided in Chapter 8 (8.10)

For availing subsidy, applicant is required to submit the NOC received from DISCOM to OREDA for processing of subsidy. As a receipt, OREDA issues a subsidy approval letter to Applicant, so that applicant can proceed for financing and installation of project.

**Figure 18: Application Screening at Discom**

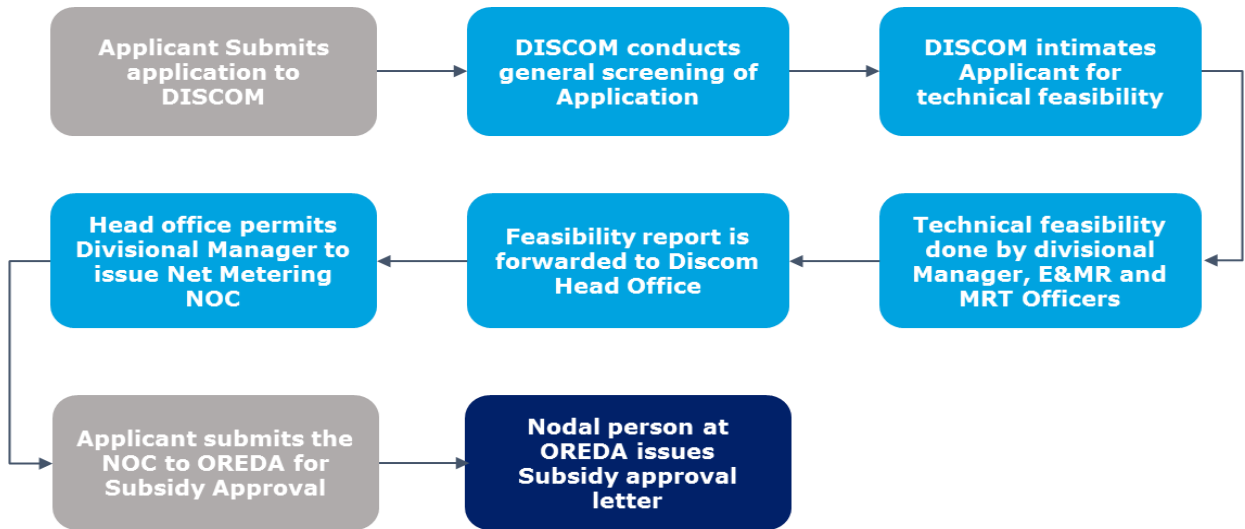

#### 4.2.4 Project Installation

On clearing the general and technical screening, applicant gets go-ahead signal from distribution utility for project installation. Project installation is the responsibility of applicant, wherein applicants identify and select appropriate vendor for system installation. Project installation also involves project procurement, wherein applicant or selected vendor on behalf of applicant does procurement of project equipment.

Project procurement should be done in accordance with utility guidelines (standards and specifications). During project installation, applicant needs to ensure that it finishes the complete project installation within timelines indicated by the utility. Utilities generally offers 90-180 days for project installation

Similar process is followed in Odisha as per the existing framework. Applicant on getting the approval from discom, selects appropriate vendor for project installation. Below figure is illustrating process of project installation in Odisha.

**Figure 19: Process of Project Installation**

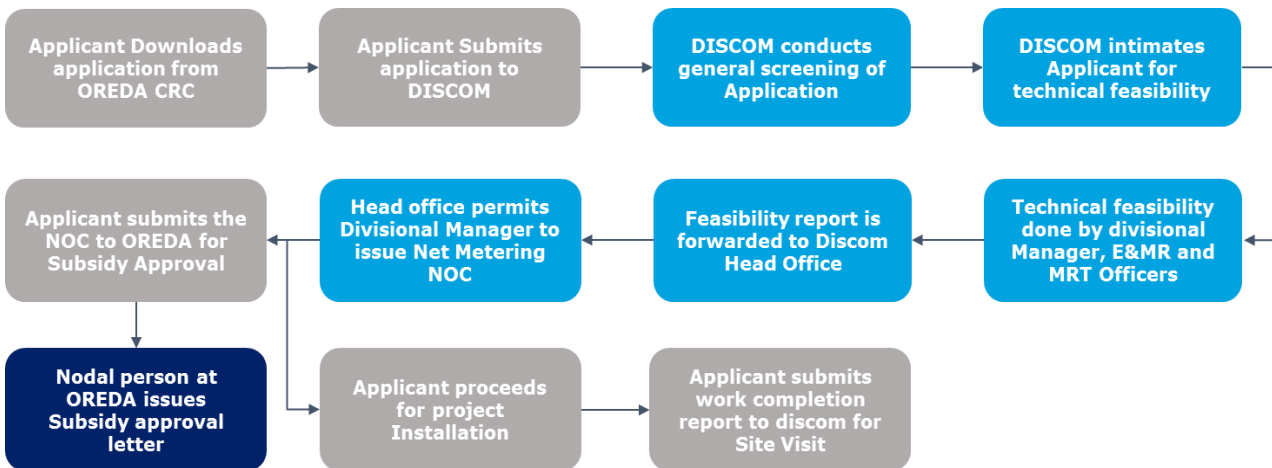

On completion of project installation, applicant with following documents request the discom for grid connectivity.

1. Approved drawings and approval for commissioning from EE of concerned discom (the approval of the same may be obtained from the Electrical Inspectorate (EI) of GoO as per prescribed regulation and its amendment from time to time).
2. Specification sheets of all equipment and test certificate as per IS/IEC standards for modules, inverters and other equipment
3. Test Certificate of bi-directional meter/Net Meter from MRT division, CESU (if meter provided by the applicant/consumer)

4. Interconnection Agreement on stamp paper as per OERC Net Metering Regulations.
5. Work completion report from system Installer (Solar Developer) certified by consumer.

#### 4.2.5 Connectivity and Synchronization

Connectivity and synchronization is final step of interconnection process. It holds high importance for applicant as well as distribution utility in terms of system safety and quality of power. The objective of this activity is to ensure that rooftop system is following the compliance with respect to measures for protection and islanding, phase sequencing, frequency and voltage variation compliance, DC injection etc.

In the existing framework, discom officials on receiving the Work Completion report, intimates the applicant for site visit to conduct the testing, commissioning and synchronization of the solar rooftop system. This is carried out by the concerned Sub-divisional/divisional Engineer along with MRT staff and E&MR staff within 8 days from the date of submission of completion report. During this step, solar rooftop system is thoroughly checked by E&MR and divisional manager prior to the commissioning and synchronization of the solar rooftop system with discom grid with suitable equipment such as Power Analyzer.

On successful testing of synchronization, a letter of synchronization is issued to the applicant by discom's Executive Engineer and a copy of the same is forwarded to discom head office for project inclusion under net metering register and further metering, billing and settlement mechanism.

Figure below illustrates the process of connectivity and synchronization in Odisha

**Figure 20: Project Connectivity Process in Odisha**

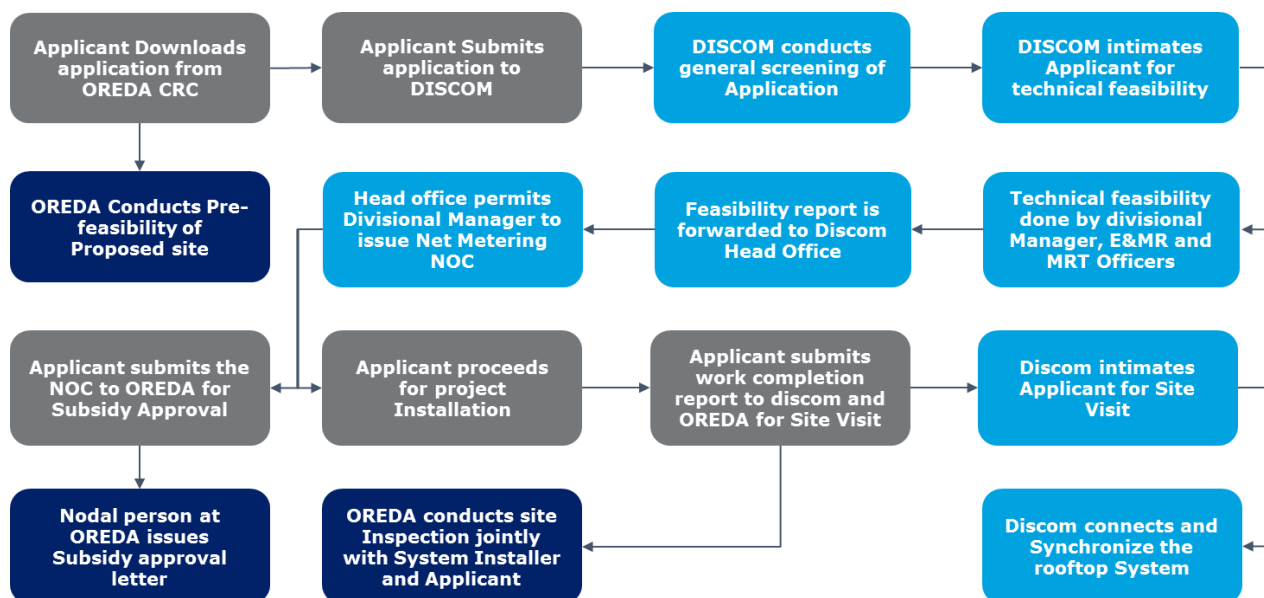

#### 4.2.6 Subsidy Disbursement

Subsidy disbursement is the final step of project completion and is considered as the most cumbersome process in India. Due to approval of various departments, availability of funds status of subsidy disbursement is quite poor in the country. To improve this situation, MNRE has recently sanctioned funds and allowed state nodal agencies to disburse subsidy on their own. OREDA under the solar city plan has also got the sanction on Rs. 9.50 Crore to support implementation of 4 MW solar rooftop capacity in the State.

To streamline the subsidy disbursement process, OREDA is planning to release subsidy through online bank transfer of funds to beneficiaries account. Disbursement of subsidy to beneficiary will be based on the nature of the project as illustrated in the figure below

**Figure 21: Subsidy Disbursement to Beneficiaries**

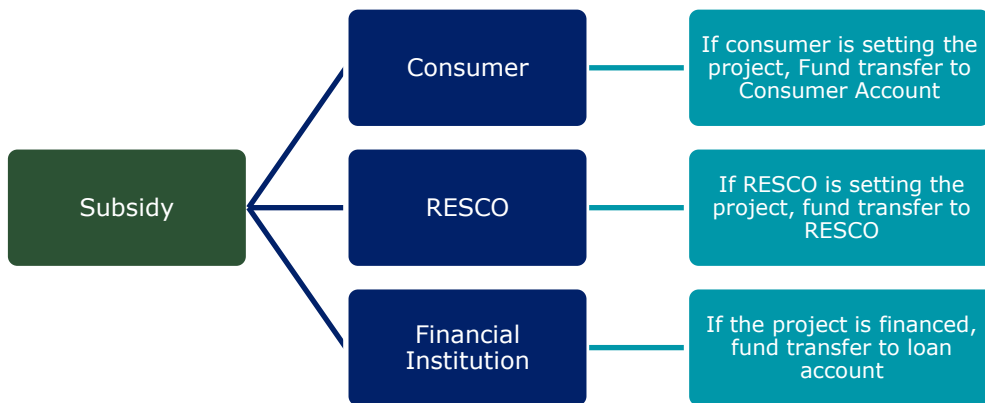

Disbursement of subsidy from state nodal agencies is done once the project is commissioned. Similar practice is followed in Odisha, wherein on completion of project installation, Applicant submits the project completion report to OREDA. OREDA on receiving the project completion report, request applicant for joint inspection with system installer.

The objective of site inspection for OREDA is to ensure the commissioning of the project. Site Inspection is carried out in presence of Assistant Director (AD), OREDA of concerned district. On satisfactory result of site inspection AD, OREDA submit its joint inspection report to the nodal officer (Deputy Director) at OREDA head office for further processing of subsidy application.

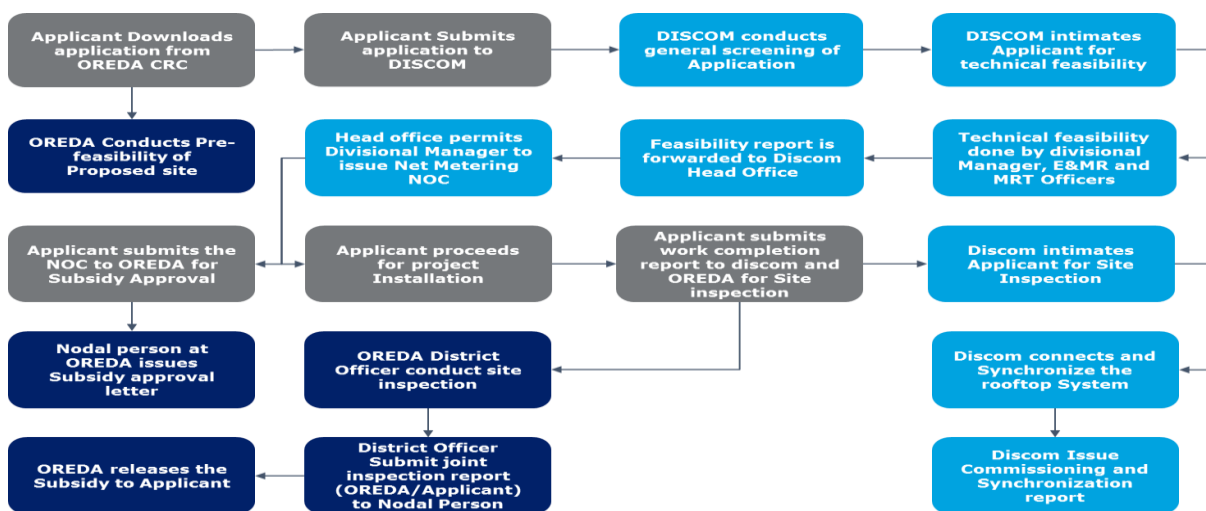

At OREDA head office, the nodal officer verifies the inspection report and on satisfactory results of inspection report it intimates the Finance department to initiate the subsidy release process. During this process, final inspection report is submitted to Finance Department, which on vetting the same, provides the approval for subsidy disbursement and moves the noting to CE-OREDA for consent. On receiving the consent of CE-OREDA, the disbursement of subsidy would take place to the intended consumer.

**4.2.7 Grievance Redressal Mechanism**

Grievance Redressal Mechanism is the key process in the whole project implementation cycle. It combines all the process and provide support to end consumer on reporting, processing and resolution of grievances with respect to solar rooftop implementation process including information access, application process, vendor selection, subsidy disbursement etc.

In the existing framework, OREDA CRC records consumer grievances through 24X7 phone help line number. Consumers can also report their complaints through web-portal as well which has dedicated section for grievances.

On submission the grievance to OREDA CRC, team leader of customer care center responds and try to resolve it at their end. If it has to be escalated than it is forwarded to the Nodal person at OREDA for proper resolution. OREDA CRC also generate weekly report on grievances and shares it to OREDA on the last day of every week (Friday). OREDA generally takes a day time to resolve the issues so that the issue get resolved before the start of next week.

#### 4.2.8 Vendor Empanelment

It is the responsibility of State Nodal agency to provide all the support to interested consumer for installation of solar rooftop and to ensure development of market within the state to promote completion and bring excellence. To ensure this, SNA support interested consumers by providing list of selected vendors having proven track record and ensure that proper service is being provided all the consumers. For selection of vendors, tender process is followed in most parts of the country. Some states directly allows MNRE Channel partners to be empaneled with them, while some adds more screening layer to select the best vendors.

Similar practice is followed in Odisha. OREDA follows the tender process and seek response from eligible vendors to provide response based on the terms of the tender within timelines. For empanelment of vendors, OREDA follows the following steps

1. Floating EOI for system integrators/ Installers of solar PV systems having valid test certificates from MNRE for Supply Installation, Commissioning and Comprehensive Maintenance of Rooftop Solar Plants.
2. Interested bidders can download the form from OREDA website and raise clarification (if required) within timelines
3. Interested bidders are called for pre -empanelment discussion generally 10 days before the bid closing date.
4. After discussion, final document is uploaded on OREDA website for bidders
5. Interested Bidder needs to prepare the bid response based on the final document uploaded by OREDA
6. If Bidder meets the eligibility criteria of EOI, it needs to submit the response with application fees (in the form of bank draft) and other documents as follows
  - a. Undertaking to unconditionally accept all terms and conditions laid in for empanelment with copy of Board Resolution
  - b. Valid document registering the status of the bidder as manufacturer /systems integrator
  - c. Organizational profile containing the original documents defining the constitution or legal status, place of registration / branches, annual off-grid and on-grid wise capacity of solar power plants installed for last 3 years.
  - d. Copy of the PAN card and TIN card
  - e. Copies of Tax returns, VAT/ e-filing
  - f. Document stating no loss certificate duly signed and stamped by a registered chartered accountant
  - g. Declaration /Original Board resolution to undertake the work under the jurisdiction of the local office
  - h. Valid Test reports of components of solar power plant from MNRE accredited test lab
  - i. Willingness to open service center in the state of Odisha and Local registered office for total execution
  - j. Undertaking for indigenoussness of the supplied items
  - k. Filled in application form along with copy of the document duly signed and stamped at the bottom of each page
7. OREDA, examines the bidder response based on the eligibility criteria and the list of documents enclosed along with the bid
8. If the bidder is clearing the eligibility criteria and has submitted the bid in the prescribed format as enclosed in the EOI, OREDA select the vendors and intimates through letter.
9. On selection, OREDA also ask bidder to submit the empanelment fees in the form of bank guarantee.
10. On submission of bank guarantee, OREDA empanels the vendor and upload their name on OREDA's web portal in the list of empaneled vendors.

## 5 Process for implementation of Solar Rooftop Projects

For implementation of solar rooftop project in Odisha, Consumer has to follow two separate processes (1) for availing Subsidy (if applicant is eligible for subsidy) (2) for availing Connectivity. This section provides the process flow of application involved in both the processes.

### 5.1 Process for Availing Subsidy

OREDA, the nodal agency of Odisha is responsible for disbursement of subsidy linked with installation of solar rooftop projects. For availing subsidy, applicant needs to register itself with OREDA. On receiving the application, OREDA district officers check the feasibility of solar rooftop at proposed location through application screening and site visit.

If the district officer is satisfied with the application and the site visit it forwards the application to the Nodal person. On receiving the application, Nodal person at OREDA issues a subsidy sanction letter to Applicant. On receiving the subsidy sanction letter, applicants proceeds with project installation and submits the project completion report to OREDA on completion of project installation. OREDA, on receiving the project completion report, OREDA district officer again goes for site inspection jointly with system installer of the rooftop project. Once the project commissioning is verified under the joint inspection report, OREDA release the subsidy to applicant on approval from finance department and CE OREDA.

Figure below is illustrating the subsidy process and indicative timelines of OREDA

**Figure 22: Process of Availing Subsidy and Timelines<sup>2</sup>**

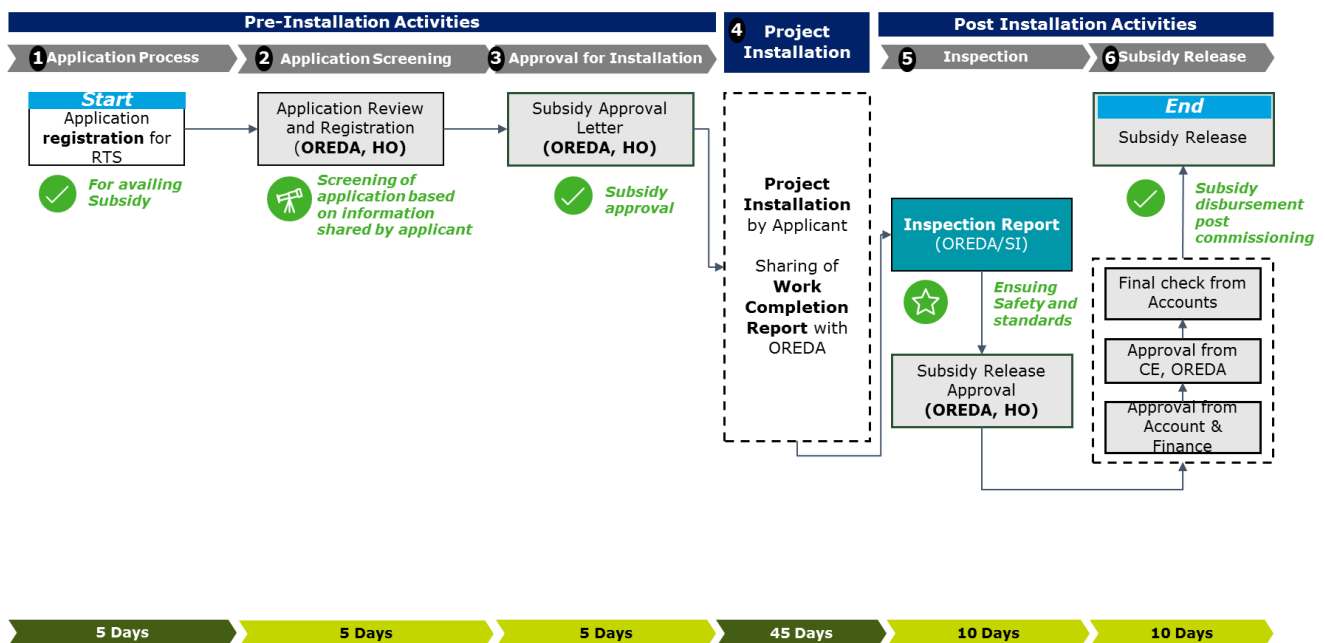

Above figure illustrated the steps involved in availing subsidy from OREDA with tentative timelines. The overall time taken for availing subsidy takes around 80 days from Zero day. This includes the overall process of registering solar rooftop system at OREDA, project installation and sharing work completion report to OREDA. Processing time of OREDA in subsidy disbursement if applicant follows the timelines properly is around 35 days.

Indicative timelines for disbursement of subsidy is given below in the table

**Table 5: Indicative Timelines for Subsidy Disbursement**

Activities	Time Required	Days from Zero Date	Milestone
Registration with OREDA	5	5	Unique Application No

<sup>2</sup> Process shown is developed in consultation with OREDA, Timelines mentioned here are indicative only not actual

Application Screening by OREDA	5	10	
Issuance of Subsidy Sanction Letter	5	15	Subsidy Approval Letter
Project Installation	45	60	Work Completion Report
Site Inspection by OREDA-System Installer and Applicant	10	70	Joint Inspection report by OREDA
Disbursement of Subsidy	10	80	Disbursement letter by OREDA

## 5.2 Process for Availing Connectivity

For Connectivity of Solar rooftop system with distribution grid, Applicant is required to file connectivity application form of respective discom. In addition to application form, applicant will also have to pay ₹500/- application fee to discom as processing charges and the acknowledgement receipt of the same has to be attached with the application form. Connectivity process followed by discom is illustrated below.

Figure 23: Process for availing Connectivity of Rooftop System<sup>3</sup>

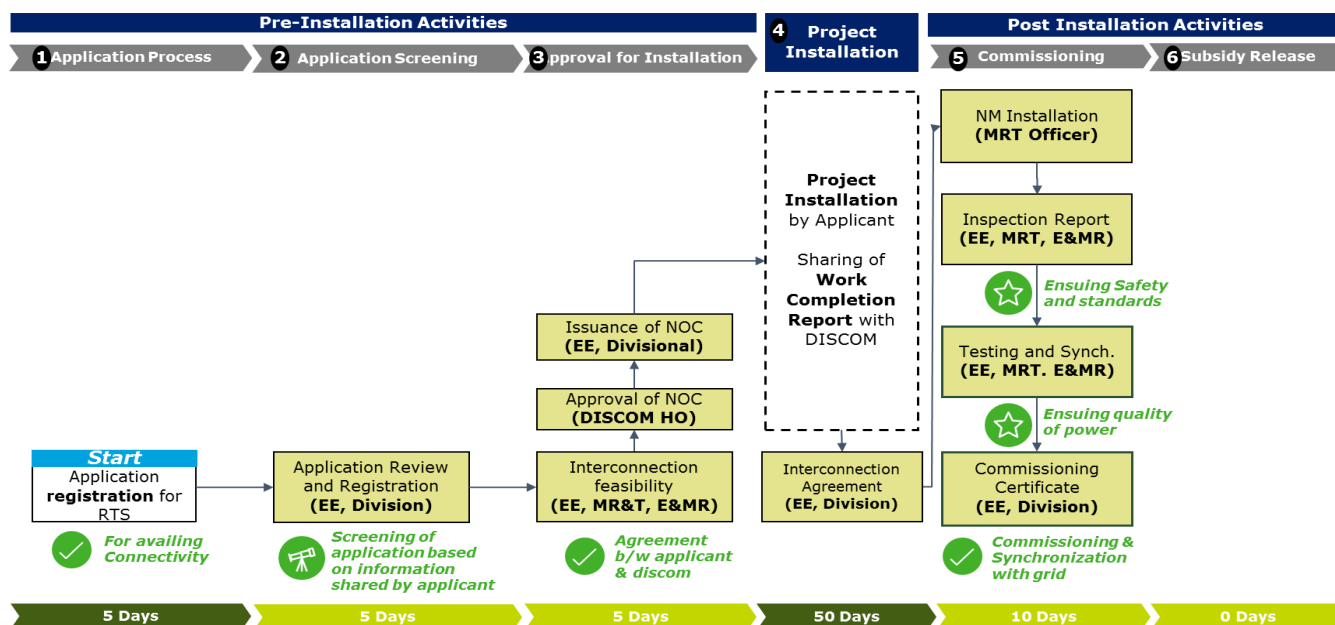

Steps involved in getting connectivity of solar rooftop are as follows

1. The applicants download the Application forms from discom website (**Format-1**).
2. The applicant submits the filled-in application along with application fees of Rs 500/- to the jurisdictional Division Office of discom.
3. On submission of application form along with all necessary documents, general screening will be done by the Division Office and application will be registered with acknowledgement to the applicant (**Format-2**).
4. The Divisional Manager along with E&MR and MRT personnel shall do the joint verification study on the technical feasibility and metering arrangement of the proposed SRTPV System within 7 days from the date of submission of application. The said technical feasibility Report (**Format-3**) shall be sent to discom head office for issuance of permission for Net Metering.

<sup>3</sup> Timelines mentioned are indicative not actual

5. On Scrutiny of technical feasibility report, Discom Head Office shall give permission to Divisional Manager to issue permission for Net Metering to the applicant (**Format-4**), if it is found technically feasible. Otherwise, the deficiencies will be intimated to Division for further communication to the applicant for the necessary compliance by the applicant/consumer.
6. Applicant shall go-a-head with project installation and shall submit the work completion report (**Format-5**) to discom with supporting documents (Approved Drawing, Specification Sheets, Meter test certificates, Net Metering agreement etc.)
7. After verification of all documents and completion reports submitted by the Applicant, Divisional Manager will issue sanction letter for testing, commissioning and synchronization of SRTPV system (**Format-6**).
8. The testing, commissioning and synchronization of the SRTPV system shall be carried out by the concerned Sub-divisional/Divisional Engineer along with MRT staff and E&MR staff within 8 days from the date of submission of completion report (in complete shape) (**Format-7**).
9. The letter of synchronization of the SRTPV system will be issued to the applicant by EE with a copy to CESU Head Office (**Format-8**).

As detailed above, the tentative time taken by Odisha discom for providing connectivity is around 75 days from Zero date. Which includes application process, feasibility study, project installation, test inspection, synchronization and charging by discom. Overall time taken by discom for approval of connectivity is 30 days from the date of submission of application by applicant. Below table is showing indicative timelines for connectivity of solar rooftop in Odisha with key milestones.

**Table 6: Indicative Timelines for Connectivity**

Activities	Time Required	Days from Zero Date	Milestone
Registration with Discom	5	5	Unique Application No
Site Visit by Divisional Manager with MRT and E&MR Officers	5	10	Feasibility Report (Signed by Divisional Manager, MRT and E&MR Officer)
Issuance of NOC by Divisional Manager	5	15	No Objection Certificate for Net metering installation
Project Installation by Applicant	45	60	Work Completion Report
Signing of Interconnection Agreement b/w applicant and Discom	5	65	Interconnection Agreement
Inspection and Commissioning of project	10	75	Commissioning and Synchronisation report

### 5.3 Process for availing both Subsidy and Connectivity

If the applicant wants to avail subsidy and connectivity both then Applicant has to apply separately to OREDA and Concerned discom. In this process, the role of OREDA is to check the feasibility of solar rooftop system at proposed site and release subsidy on achieving of particular milestones by applicant. While to role of discom is to check the interconnection feasibility and output of solar rooftop for connectivity with the grid. The Overall process of availing subsidy is illustrated below.

**Figure 24: Process flow for applicant availing Subsidy and Connectivity**

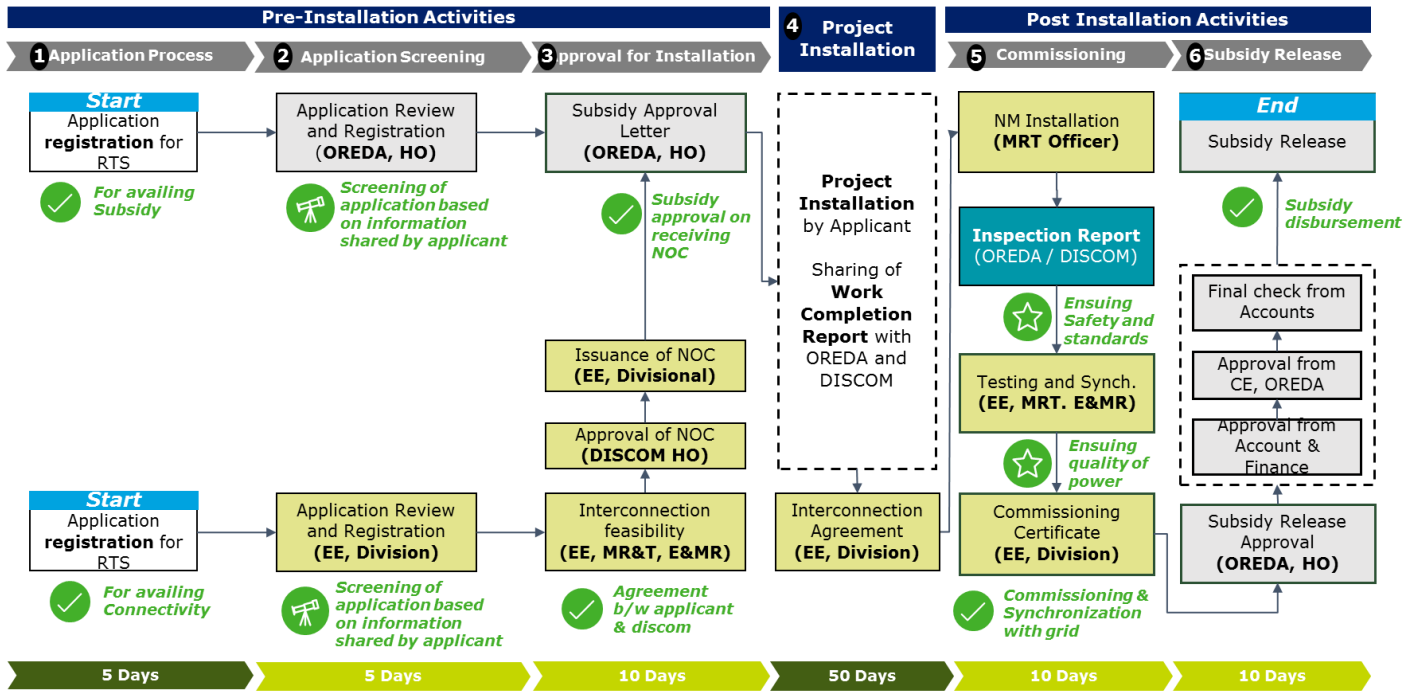

Indicative timelines for applicant wanted to avail subsidy and connectivity of solar rooftop are as follows

**Table 7: Indicative timelines for Connectivity and Subsidy Application**

Phase	Activity	Total days
1. Application Process	1. Application to OREDA	5
	2. Application to DISCOM	
2. Application Screening	1. Application Screening at OREDA	5
	2. Application Screening at DISCOM	
3. Installation Approval	1. Interconnection Feasibility Check by DISCOM	2
	2. NOC approval from DISCOM HO	1
	3. Issuance of NOC by EE, DISCOM	2
	4. Issuance of Subsidy Sanction Letter	5
4. Project Installation	1. Installation of RTS Project by Applicant	45
	1. Signing of Interconnection Agreement by DISCOM	5
	2. Installation of Net Meter	10
3. Site Inspection Report		
2. Testing and Commissioning		
5. Inspection & Commissioning of RTS	3. Issuance of Commissioning Certificate	
6. Subsidy Release	1. Subsidy Release by OREDA	10
<b>Total Processing time from Zero Date</b>		<b>90</b>
<b>Processing time for Administrative Approvals</b>		<b>45</b>

## 6 Proposed process for implementation of Solar Rooftop through web application

Based on discussion with implementing agencies (OREDA and DISCOM (CESU)) rooftop implementation process through web application has been developed. Similar to the existing process, process flow of application under three different scenarios have been developed i.e.

1. Process for availing Subsidy (for Off-grid/Captive Projects)
2. Process for availing connectivity (for RTS projects not eligible for subsidy)
3. Process for availing both subsidy and connectivity (Net Metering based RTS project with subsidy)

Detailing of each process is captured in the following sections

### 6.1 Process for availing subsidy

The process flow of application for availing subsidy is illustrated below for applicant who intends to install a captive/off-grid RTS project and is eligible for MNRE subsidy. Steps involved in the process are illustrated below

**Figure 25: Process flow for availing subsidy<sup>4</sup>**

1. **Application Process:** In this process, Applicant before filling the application form will gather all the information with respect to key equipment, estimation of solar resource assessment, estimation of savings, business models, empaneled vendors etc. After getting all this information, applicant will select one of the empaneled vendor and will fill the registration form along with MNRE subsidy form. On

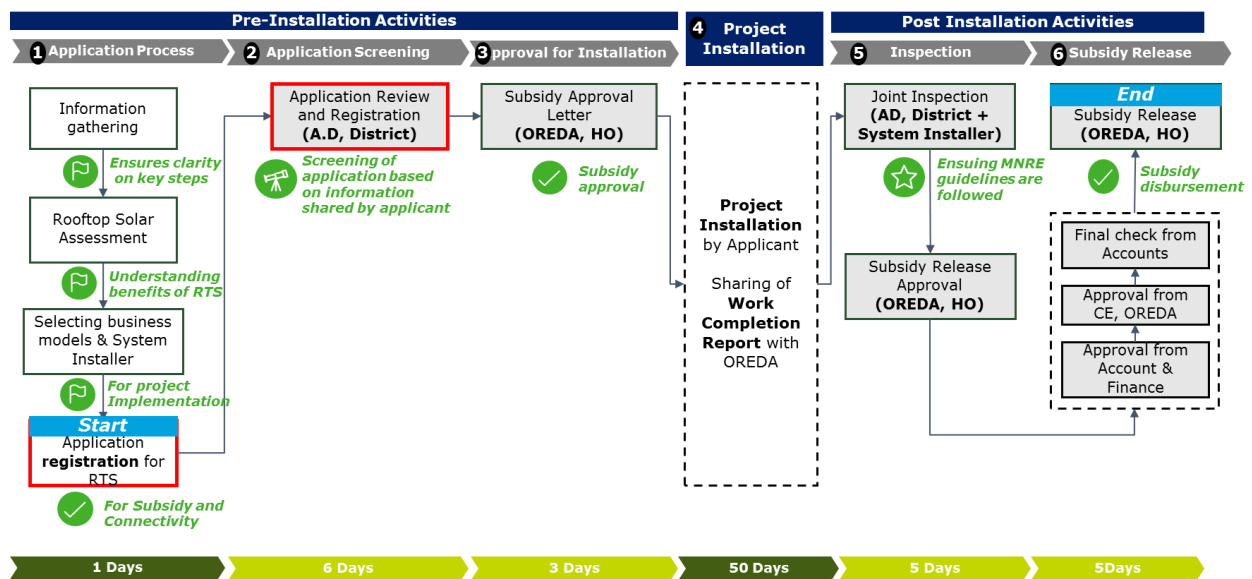

filling the complete application form, Applicant will submit it. On submission of application form, applicant will receive an acknowledgement from OREDA for receiving of application form.

2. **Application Screening:** At OREDA, Application will come to Assistant Director, OREDA of concerned district. It will screen the application form and will evaluate the feasibility of solar rooftop and subsidy based on the information provided by the applicant in application form. If the application is complete and correct in all sense it will forward it to the Nodal officer at OREDA head office.
3. **Approval for Installation:** At OREDA head office, the nodal person will approve the application form upon which a system generated “subsidy sanction letter” will be forwarded to applicant on its registered email ID and mobile number.

<sup>4</sup> Timelines indicated below are based on the discussions with implementing agencies and considering third party interventions for application screening and site inspection

4. **Project Installation:** On receiving the subsidy sanction approval, applicant will proceed for project installation and will upload a work completion report on web tool on completion of project installation. Project completion report will come to concerned district officer (A.D) for site inspection
5. **Site Inspection:** On receiving the work completion report, district officer OREDA will schedule a site visit with system installer and applicant. During inspection, OREDA officer will check the compliance of MNRE standards and guidelines and commissioning of RTS project. On satisfactory result of inspection, OREDA officer, System Installer and Applicant will sign a joint inspection report. Joint inspection report will be uploaded by concerned district officer on web tool which in turn will be reviewed by the nodal person.
6. **Subsidy Release:** On satisfactory result of joint inspection report, the Nodal person will approve the report and the complete file will go to accounts department for release of subsidy. Accounts department will check the compliance of all the relevant documents required for release of subsidy and will forward the file to CE, OREDA for final approval of subsidy. On receiving the approval from CE, OREDA, accounts department finally releases the subsidy to applicant.

The overall time taken in the whole process will be 68 days including 50 days of project installation and 18 days for administrative approvals.

### 6.2 Process for availing Connectivity

The process flow of application for availing connectivity is illustrated below for applicant who intends to install a grid tied RTS project but is not eligible for MNRE subsidy. Steps involved in the process are illustrated below

**Figure 26: Process for Availing Connectivity**

1. **Application Process:** In this process, Applicant before filling the application form will gather all the information with respect to key equipment, estimation of solar resource assessment, estimation of savings, business models, empaneled vendors etc. After getting all this information, applicant will select one of the empaneled vendor and will fill the registration form, on filling the registration forms DISCOM connectivity application will be automatically filled. On filling the complete application form, Applicant will deposit connectivity fee through online/offline mode and will upload the acknowledgement receipt on web tool for reference. On uploading payment receipt, applicant will receive an acknowledgement from DISCOM for receiving of application form and processing fees.
2. **Application Screening:** At DISCOM, application form will come to divisional level, of concerned discom. Based on the capacity of project, application will be screened by Junior Engineer/Assistant Engineer/ Executive Engineer. Divisional officer will screen the application based on payment receipt,

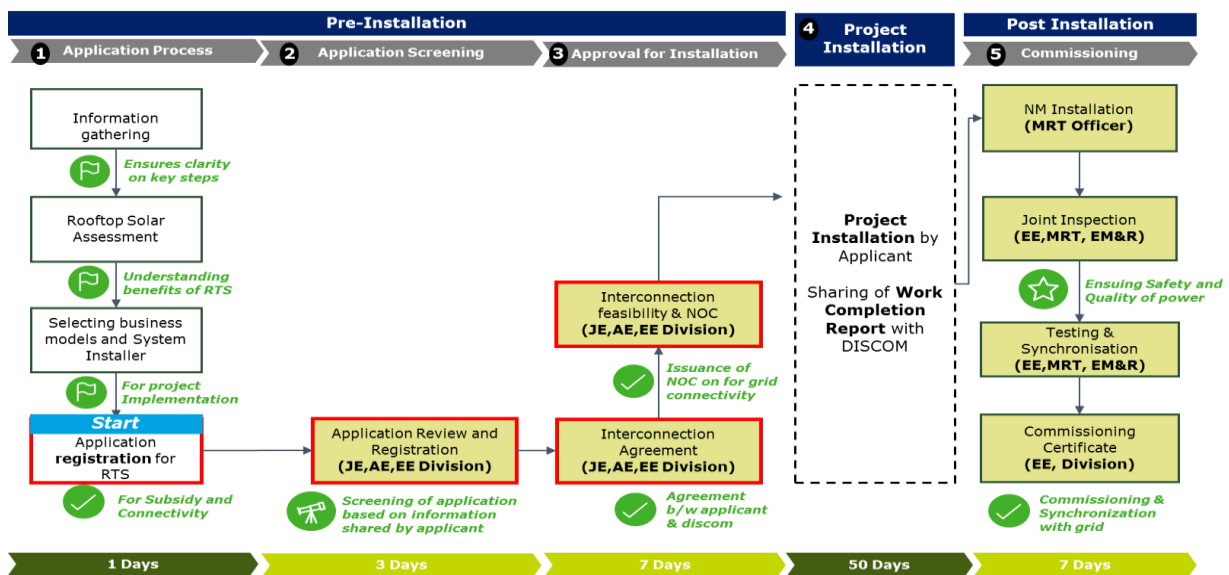

connected load, proposed capacity etc.

3. **Approval for Installation:** After application screening, applicant will sign interconnection agreement with divisional officer. After signing of agreement, divisional officer will check the interconnection feasibility of proposed rooftop system and will prepare a feasibility report. On satisfactory result of feasibility report, divisional engineer will approve the application forms. On approval of application form a system generated “No Objection Certificate” for grid connectivity will be forwarded to applicant on its registered email ID and mobile number.
4. **Project Installation:** On receiving the NOC, applicant will proceed for project installation and will upload a work completion report on web tool on completion of project installation. Project completion report will come to concerned divisional officer (JE/AE/EE) for site inspection.
5. **Site Inspection:** On receiving the work completion report, divisional officer of DISCOM will schedule a site visit with MRT (Meter reading and testing) and E&MR division of DISCOM. Before inspection, MRT officers will first install net meter and then MRT along with other discom officers will inspect the compliance of OERC/CERC/CEA standards and guidelines for RTS project. All discom officers will jointly prepare an inspection report and on satisfactory result of inspection, they go for test commissioning and synchronization of RTS project with grid.
6. **Connectivity:** Joint inspection report signed by discom officers will be uploaded by the divisional officer on web tool, upon which a commissioning certificate will be generated which will be forwarded to applicant on his registered Email ID.

The overall time taken in the whole process will be 68 days including 50 days of project installation and 18 days for administrative approvals.

### 6.3 Process for availing both Subsidy and Connectivity

The process flow of application for subsidy and connectivity is illustrated for applicant who intends to install a net metering based RTS project and is also eligible for MNRE subsidy. In this process, both the processes described above will run in parallel. Discom will process the application for connectivity and OREDA will process the application for subsidy. Steps involved in the process are illustrated below

1. **Application Process:** In this process, Applicant before filling the application form will gather all the information with respect to key equipment, estimation of solar resource assessment, estimation of savings, business models, empaneled vendors etc. After getting all this information, applicant will select one of the empaneled vendor and will fill the registration form and MNRE Subsidy forms. On filling the registration forms DISCOM connectivity application will be automatically filled. On filling the complete application form, Applicant will deposit connectivity fee through online/offline mode and will upload the acknowledgement receipt on web tool for reference. On uploading payment receipt, applicant will receive an acknowledgement from DISCOM for receiving of application form and processing fees and from OREDA for receiving MNRE subsidy form.
2. **Application Screening:** At OREDA, Application form will come to Assistant Director, OREDA of concerned district. It will screen the application form and will evaluate the feasibility of solar rooftop and subsidy based on the information provided by the applicant in application form. If the application is complete and correct in all sense it will forward it to the Nodal officer at OREDA head office. While at DISCOM, application form will come to divisional level, of concerned discom. Based on the capacity of project, application will be screened by Junior Engineer/Assistant Engineer/ Executive Engineer. Divisional officer will screen the application based on payment receipt, connected load, proposed capacity etc.
3. **Approval for Installation:** At DISCOM, after application screening, applicant will sign interconnection agreement with divisional officer. After signing of agreement, divisional officer will check the interconnection feasibility of proposed rooftop system and will prepare a feasibility report. On satisfactory result of feasibility report, divisional engineer will approve the application forms. On approval of application form a system generated “No Objection Certificate” for grid connectivity will be forwarded to applicant on its registered email ID and mobile number. While at OREDA, after application

screening is done the nodal person at OREDA head office will approve the application form after ensuring NOC from DISCOM. Upon which a system generated “subsidy sanction letter” will be forwarded to applicant on its registered email ID and mobile number.

- 4. Project Installation:** On receiving the subsidy sanction approval and NOC from DISCOM, applicant will proceed for project installation and will upload a work completion report on web tool on completion of project installation. Project completion report will come to concerned district officer (A.D) OREDA and divisional officer of DISCOM for site inspection.
- 5. Site Inspection:** On receiving the work completion report, both OREDA officer and divisional officer of DISCOM will schedule site visit (separately). Discom will inspect the project with respect to safety and quality of power while OREDA will inspect the project with respect to compliance of MNRE Subsidy. Both the agencies will prepare separate inspection report and will upload to the web tool for further processing of application.
- 6. Commissioning:** After Joint inspection, an inspection report signed by discom officers (EE, MRT and E&MR) will be uploaded by the divisional officer on web tool, upon which a commissioning certificate will be generated which will be forwarded to applicant on his registered Email ID.
- 7. Subsidy Release:** After site inspection by OREDA, OREDA officer will sign a joint inspection report with applicant and system installer. And will upload the same for review of nodal officer at OREDA head officer. On satisfactory result of inspection report, the Nodal person will approve the report and issue a subsidy disbursement letter to applicant. After this, the complete file will go to accounts department for release of subsidy. Accounts department will check the compliance of all the relevant documents required for release of subsidy and will forward the file to CE, OREDA for final approval of subsidy. On receiving the approval from CE, OREDA, accounts department finally releases the subsidy to applicant

Figure 27: Process flow for application for Connectivity and Subsidy

6.4 Indicative timelines for processing of application with web application

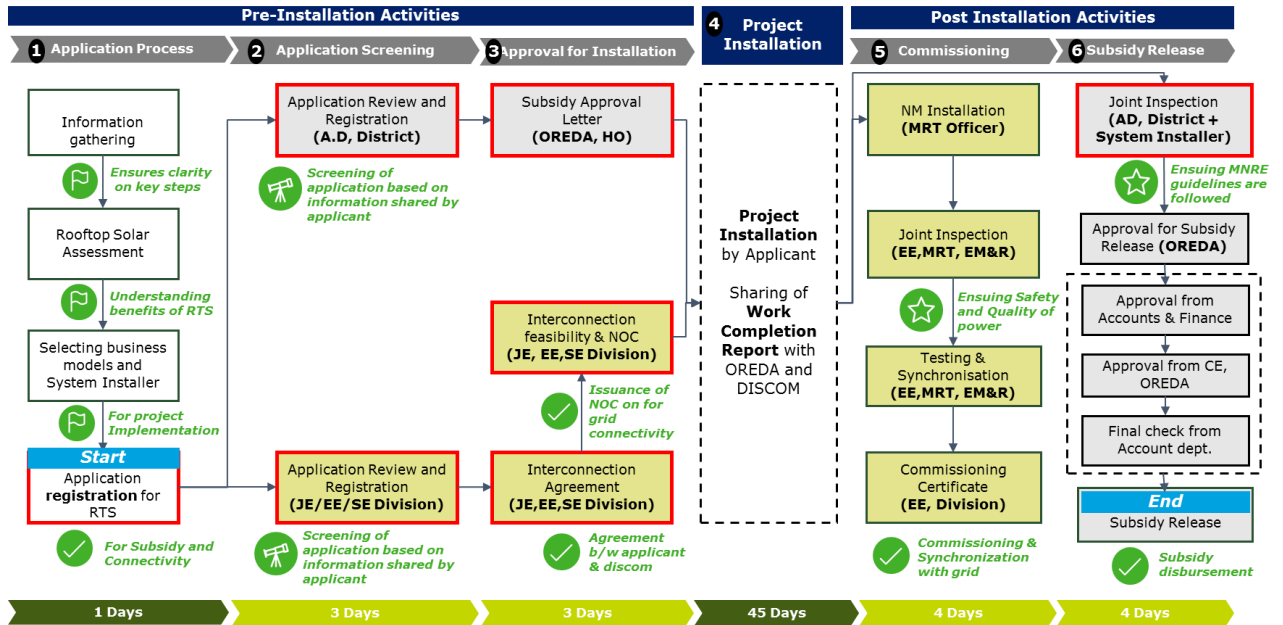

Phase	Activity	Subsidy (1)	Connectivity (2)	Both (3)*
<b>1. Application Process</b>	1. Application to OREDA	1	*	1
	2. Application to DISCOM	*	1	1
<b>2. Application Screening</b>	1. Application Screening at OREDA	6	*	6
	2. Application Screening at DISCOM	*	3	3
<b>3. Installation Approval</b>	1. Signing of Interconnection Agreement by DISCOM	*		
	2. Interconnection Feasibility Check by DISCOM	*	7	7
	3. Issuance of NOC by DISCOM	*		
	4. Issuance of Subsidy Sanction Letter	3	*	3
<b>4. Project Installation</b>	1. Installation of RTS Project by Applicant		50	50
	1. Installation of Net Meter	*		
	2. Inspection by DISCOM	*		
<b>5. Site Inspection</b>	2. Testing and Commissioning	*	7	7
	3. Issuance of Commissioning Certificate	*		
	1. Inspection by OREDA	5	*	5
<b>6. Subsidy Release</b>	2. Subsidy Release by OREDA	5	*	10
	<b>Total Processing time from Zero Date</b>	<b>70</b>	<b>68</b>	<b>85</b>
<b>Processing time for Administrative Approvals</b>		<b>20</b>	<b>18</b>	<b>35</b>

\* Some of the OREDA and DISCOM activities will run in parallel

## 7 Assessment of OREDA's IT arrangements

With a view to understand the existing IT arrangement of OREDA, it would be prudent to segregate the arrangement as following:

- Internal IT infrastructure and services
- External IT infrastructure and services

The internal IT infrastructure and services comprises of the IT apparatus which exists to cater the communication process internally within OREDA. It serves as the network to support information repository, exercise system controls and ensure tracking of the communication through proper monitoring and verification protocol.

The external IT infrastructure and services encompasses two OREDA websites namely- ([www.oredaodisha.com](http://www.oredaodisha.com)) and ([www.odisharenewable.in](http://www.odisharenewable.in)) platform and its associated infrastructure. The above mentioned websites acts as an interface between the prospective consumers and OREDA and serves as a conduit for information dissemination on renewable energy development in the state.

### 7.1 Evaluation of the existing IT infrastructure and services

Based on interaction with the OREDA and relevant stakeholders- contractors for the ([www.oredaodisha.com](http://www.oredaodisha.com)) and ([www.odisharenewable.in](http://www.odisharenewable.in)) respectively, assessment of the existing internal and external infrastructure and services was performed.

- IT infrastructure and services for ([www.oredaodisha.com](http://www.oredaodisha.com))- OREDA had appointed M/s.Suryanandan.net to develop the illustrated website. The website had been developed on the open source and by employing the Windows platform. The website is hosted on the shared server and occupies 3-4GB space. Also, the control over the domain and space lies with the contractor whereas the website is registered with OREDA.
- IT infrastructure and services for ([www.odisharenewable.in](http://www.odisharenewable.in))- OREDA through a competitive bidding process, selected M/s. Parameter Softwares Pvt. Ltd. (PSPL) to setup and operate a customer relationship center called "OREDA Customer Relationship Center" for a contract period of five years starting in October,2015. The registration and ownership of the domain name is with selected vendor and web application is built on Linux platform, which is an open application. OREDA CRMS is hosted on shared Linux based web server and the ownership of server lies with the selected vendor
- Internal IT Infrastructure and services- In the existing arrangement, there are two HP servers being controlled and registered with OREDA. Both the servers have each 6GB RAM space.

### 7.2 Evaluating existing IT Contracts

#### 7.2.1 OREDA Customer Relationship Management Solution (CRMS)

The Customer Relationship Management Solution tool, through a helpline service, facilitates consumers using different renewable energy applications by providing end-to-end solution for managing and aggregating customer feedback to complaints and redressal along with sending timely reminder to the hardware vendors and their AMC service providers to ensure that the experience involving the use of RE is a pleasant one.

OREDA through a competitive bidding process, selected M/s. Parameter Softwares Pvt. Ltd. (PSPL) to setup and operate a customer relationship center called "OREDA Customer Relationship Center" for a contract period of five years starting in October,2015. The activities identified to be taken up by PSPL under the OREDA CRMS contract is as follows;

1. **To design and develop a web portal ([www.odisharenewable.in](http://www.odisharenewable.in)) for general public and customers and maintaining it with latest and relevant information.**
  - a. The web portal to act as a *web interface to the general public*, those who want service and for the existing customers for requesting services or to track the progress of their request
  - b. The web portal with all possible extension is to be *registered by OREDA* and the *controls to be handed over to PSPL*. The site has to be developed and maintained by PSPL for the period of the contract
  - c. The site for the general public shall carry information in an attractive way. All the relevant news concerning renewable energy, recent developments, Govt. policies. It should also carry news and publicity material of new schemes promoted by government. Web portal should also have blogs having news/updates for public to augment their knowledge and interest. These updates

should also be automatically published in various social media sites like Facebook and Twitter or any other popular platforms. Increasing number of likes of these social media pages of OREDA is also the responsibility of PSPL.

- d. The web portal should also provide FAQs with respect to various schemes and provide relevant information for ease of taking informed decision. Online registration form should be supported by site instructions, FAQ, Capacity calculator, financial viability calculator, hardware selection steps
- e. The registered application should automatically be tracked till their installation is made and they are brought into the customer database

**2. *Design, develop and customize an automated customer relationship management system and manage it.***

- a. A CRMS to be customized and developed to accommodate the existing customers of OREDA without entering the existing structures and processes and also the new customers registering through the On-line or annual application process.
- b. A database of customers across various schemes and departments will be given by OREDA to be ported onto the CRMS
- c. Periodic updation of new customers is the responsibility of PSPL
- d. The database of registered suppliers who are mandated to provide service to the customer will be supplied to PSPL by OREDA
- e. PSPL to develop and automated service request handling process which will capture requests coming from customers through various channels and forward it to the concerned service providers and track the process to ensure timely compliance, the channels can be voice, email and registered mobile numbers
- f. The software should be able to monitor registration to resolution process automatically and raise alerts for overdue cases and escalate the same for resolution or interventions or administrative actions.
- g. The date and time of transactions with regards to raising a ticket with a request for service to final fixing has to be captured and a robust MIS to be developed to analyse various entities in terms of their services quality and gap has to be incorporated into the system
- h. The application has to be webhosted and developed by using open source products
- i. Depending upon future requirements, PSPL would be asked to develop additional features and cover additional scope of work which will be paid for separately at a negotiated price

**3. *Establish a customer relationship center of a given specification and manage it.***

- a. A dedicated independent space for the CRC to be put up away from the OREDA headquarters
- b. It should be fully furnished with AC and power backup facility
- c. The CRC should be of a five seat for inbound calls
- d. The CRC will be provided with an official landline by OREDA and a toll free number for which the monthly rent and bills will be paid by PSPL
- e. PSPL to take webserver for hosting the application, website and database on behalf of OREDA and control and manage the same for the period of contract
- f. PSPL to identify a team lead of the CRC, who in turn has to deal with the nodal officer nominated by OREDA not below the rank of a deputy director to supervise this project on daily basis

As per the contract, the information sharing within the application software has to be with the designated officers through high accesses at OREDA. Data communication is done through emails. After the expiry of contract, PSPL will hand over the application software to OREDA with all the rights to use and make changes in the application. As per the contract, OREDA also has the complete right to terminate the contract after PSPL is served three consecutive notice of non-performance.

**7.2.2 OREDA Mobile Application (Proposal)**

In order to create a master database of existing customers and suppliers, PSPL has submitted a proposal OREDA for developing three mobile applications for creation of data base of OREDA's existing customers, Suppliers and RE installations. The mobile application will sync all this information with existing CRMS web application so that CRMS has the data base of all OREDA's customers and suppliers so that their queries are properly addressed.

As per the proposal, the scope of the mobile application is to integrate the process of Survey, Supplier management, Installation process and backend support and work in synch with the existing CRMS (Customer Relationship Management Centre) application. The mobile application is proposed to be developed on Android platform using HTML/XML codes with MySQL as the database.

Mobile application will be used by OREDA's suppliers during survey of OREDA's prospective customers. Suppliers will feed all the generic and technical details on behalf of customers for household electrification, solar PV rooftops, rural drinking water, lift irrigation installation etc. The mobile application will have details of customers, suppliers, equipment installed at a particular site etc. and will be synchronized periodically with CRMS application.

The proposed services under the proposal are as follows

1. Match it to the CRMS Contract period
2. Share upgrades and Additional features
3. Backend Data Management
4. Training support to the users

As a part of deliverable, the proposal is to provide three mobile applications individually for Survey, Supplier and Installation data. To start with survey application will be launched followed by supplier and installation module on successful testing of survey application.

### **7.2.3 SMS Notification Feature (Proposal)**

To facilitate existing customers of OREDA, PSPL has submitted a proposal for adding SMS notification feature to existing CRMS application of OREDA. The objective is to provide mobile based communication support to customers in addition to web based communication (E-mails). This would largely help customers, technicians operating in remote areas where internet is not available.

As per the existing arrangement CRMS application is communicating with the stakeholders over e-mails to OREDA and service providers. But some of the suppliers working in remote areas are not able to get email notifications, based on their feedback it is proposed to integrate SMS notification facility to the current CRMS application whereby the transactions are notified to the concerned stakeholder to which they respond appropriately.

To implement this facility, PSPL proposes upgradation of existing CRMS application to facilitate SMS Notification. Further, it will also require deputation of CRC representative at OREDA for coordination and integration with OREDA's functioning on a regular basis.

### **7.3 Evaluating Manpower requirement for program implementation**

In the current framework, a fresh application filed for rooftop installation will go for technical review and feasibility to the Technical Department. Lower offices of Technical assistant/Jr, technical assistant/Jr. Engineer will carry out the detailed feasibility study and report upward to section officer and assistant director (tech.). Once found feasible it will move to administrative department for a sanction approval. Sanctioned project will be implemented by engineers of technical department. Upon commissioning it will be jointly reviewed by higher echelons of director rank and above after whose confirmation the final disbursement of subsidy will be made by the finance department to beneficiaries account. An applicant during any stage of process has the right to know the status and necessary information for which he has to write to assistant director (information).

In addition to the hierarchical set up defined within OREDA and as per the information from OREDA, there are 13 offices spread across 30 districts of the state looking after the scheme of things.

The below illustration depicts the current organization set up within OREDA.

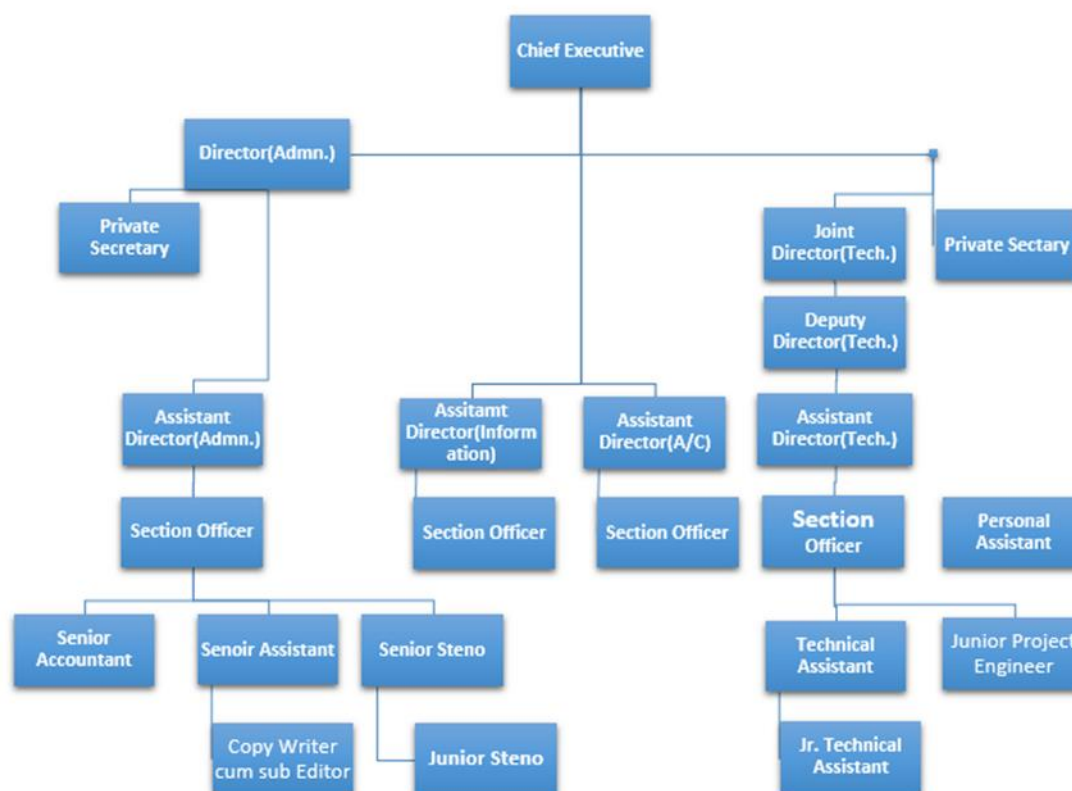
**Figure 28: Organization Chart of OREDA**

Govt. of India, is driving one of the fastest Solar Program of 100 GW capacity by 2022 has allocated 2.19 GW to Odisha, wherein target for Rooftop Solar (RTS) is 1 GW. For FY 2017-18, target of installing 4 MW of solar in city of Bhubaneshwar has been earmarked. With such targets in place and on assuming average rooftop installation of 10kW to be developed, we expect over 400 applications from across the city coming to OREDA looking forward for reviews, approval and support in project implementation. Also, it needs pertinent mentioning that on program replication across different cities in the state, the challenge of carrying out the entire scheme of conducting review to according approval would be immense. Taking this forward, with limited presence of OREDA staff across the 30 districts of the state- supporting the entire project management from OREDA would be an uphill task.

Therefore, smooth implementation of the program necessitates that additional staff needs to be deployed to perform all the necessary functions well within the stipulated time limits. Alternatively third party vendors with specialization in their field can be outsourced the work of assessment and review thereby ensuring that no compromise is made of technical work quality while no additional burden falls on finances of OREDA that may otherwise have to significantly expand its capacity.

Six levels from junior assistant to Chief executive means that there will be significant time consumption as files moves through the hierarchical setup. More linear structure instead of pyramidal command flow means that there can considerable be duplication of approval work at assistant Director level and above while understaffing at section's office and below will mean delay in application review. Contractualization to a third party will pass on the entire task to the contractor who can be held liable for any shortcoming in service delivery and OREDA will be better able to focus on overall supervision and management.

## 7.4 Review of Existing IT Arrangement Key Gaps

### 7.4.1 Strength

Till date, the existing IT set up of OREDA has been instrumental in carrying out the proliferation of renewable energy applications across the state. The current IT interface provides enriched knowledge on the current achievement of state in the renewable space of the state. Also, it stands out to be one point connect for sourcing information on the latest development in the renewable energy segment. Additionally, OREDA-CRMS has been effective in handling the customer related queries with regards to using and employment of renewable energy sources.

### 7.4.2 Weakness

It is understood that from the perspective of solar rooftop development in the state, there is a significant limitation in the current IT arrangement. Therefore, a gap analysis has been carried out based on the review of existing contracts of OREDA CRMS and overall IT infrastructure considering key aspects and features which are as follows:

- Robustness
- Replicability & Sustainability
- Data confidentiality
- Multifaceted

S No	Particular	Feature	Gap	Impact
1	Existing Contract of OREDA-CRMS	Robustness	Controls of the OREDA –CRMS application lies with the contractor throughout the period of contract	Provisioning controls to the contractor under the contract may give him the free run to operate with an apprehension of prejudice creeping in system during long run
	IT Infrastructure		External web application has limitation to handle large traffic in long run	All the external web application is hosted on shared webserver. Considering huge interest from applicants and the scale at which OREDA wants to implement the web application, shared server may not be able to handle the anticipated traffic in a long run
2	Existing Contract	Replicability & Scalability	Controls of the OREDA –CRMS application lies with the contractor throughout the period of contract	Provisioning controls to the contractor under the contract may impede the objective of OREDA with regards to replicating and scaling the program across the state
	IT Infrastructure		In the existing arrangement, ownership of domain name and server is with selected vendor	With OREDA having no control, it poses a great risk in terms of the sustainability and replicability of external web applications
3	Existing Contract	Data Confidentiality	OREDA –CRMS application lies with the contractor throughout the period of contract	Provisioning controls to the contractor under the contract may lead to spilling and pilferage of confidential customer data
	IT		CRMS web application is webhosted and developed on open source products	Being hosted on the open source, it possess a great risk to the confidentiality of information shared by applicants with OREDA
4	Existing Contract	Multifaceted	The scope of work defined under the contract confines the development of web tool enabling participation of only OREDA and customer	The current scope of work defined in the contract does not provide the flexibility to consumer of using the CRMS platform for seeking grid connectivity and redressal of grievance with regards to grid inter-connection

S No	Particular	Feature	Gap	Impact
	IT		External platform particularly CRMS application caters to the need of applicants who are willing to avail the benefit of MNRE subsidy with regards to rooftop projects	Limits the larger participation of other stakeholders particularly CESU resulting in impeding the development of rooftop projects only meant for grid connectivity.

Clearly, the current arrangement has limitation in carrying forward the proliferation of rooftop implementation in the state. Therefore, a well desired IT arrangement developed under water tight contractual arrangement and with necessary features is a definite requirement.

### 7.5 Way Forward- Scoping need for web tool.

Considering the gaps identified above, it becomes imminent and holds paramount importance to create a new web application, which is robust, secure, dynamic, stakeholder interactive and multi-faceted. The new web should integrate key stakeholder viz. OREDA, DISCOM, Applicant and Channel Partners, System integrators etc. at a single platform. This would help them to understand and perform their shared roles and responsibilities in proliferation of the renewable applications across the state. The web tool should also be designed and developed under a robust contracting arrangement which would authorize OREDA to exercise complete control over it. The web tool although being interactive should be firewalled with high end security layers to enable the security of the relevant information of applicants. Thus, in order to make the new web application up and running at OREDA's end, below are the prerequisite with regard to the web tool development:

- One domain on which portal will be hosted like (WWW.xyz.com)
- SSL certificate for the domain name (recommend)
- OS Windows 2012 R2
- IIS with .net framework 4.5 and above
- DB: MS SQL Server 2012
- MS SQL Server Reporting services
- Space : 100GB(depend on volume of data)
- Accessibility to servers for the hosting the applications and Database.

## 8 Gaps and Key Recommendations

This section covers the gaps based on detailed analysis of existing framework and also propose recommendations to make it model framework for implementation of solar rooftop in Odisha. Table below provides a gaps in existing framework in the form of checklist;

**Table 8: Gaps in Odisha Rooftop Implementation Framework**

S. No	Implementation Framework Requirements	Checklist
<b>1.</b>	<b>Information Access</b>	
	• Resource Assessment	✗
	• Description of key Equipment	✓
	• Cost Economics of Solar Rooftop	✗
	• Available Business Models	✗
	• Project Planning guidelines	✗
	• State and Central Govt. Schemes	✗
	• Process Flow of subsidy and Connectivity	✗
	• Guidelines for Interconnection	✗
	• Single Line diagram of Rooftop System	✓
	• List of Empaneled Vendors	✓

	• List of Empaneled Meter vendors (online)	x
	• Metering arrangement & Location	x
	• Standards for PV Modules & BOS	✓
	• Specification for Inverter	✓
	• Metering Standards & Accuracy	✓
	• Security Measure Checklist	x
	• Operation and Maintenance guidelines	x
	• Help Line Number	✓
	• Process of approvals and clearances	x
	• Forms/Format for Connectivity	x
<b>2.</b>	<b>Application Process (OREDA)</b>	
	• Online Application Access	✓
	• Online Application Submission (limited features)	✓
	• Online Payment	x
	• Online Application Approval	x
	• Contact Details of Nodal Person	x
	• List of documents for Subsidy	x
	• Application Status	x
	• Process Map of Subsidy Disbursement	x
<b>3.</b>	<b>Application Process (Discom)</b>	
	• Online Application Access	✓
	• Online Application Submission	x
	• Online Payment	x
	• Contact Details of Nodal Person	x
	• Online application approval	x
<b>4.</b>	<b>Processing of Application</b>	
	• Guidelines for processing of application with timelines	x
	• Site inspection	✓
	• Screening Criteria	✓
	• Procedure for Screening & Selection	✓
<b>5.</b>	<b>Approvals and Clearances</b>	
	• List of approval and clearances on Website	x
<b>6.</b>	<b>Post Installation Support</b>	x
	• Grievance Handling Mechanism at OREDA	✓
	• Grievance Handling Mechanism at Discom	x

Gaps identified above are from the view of making existing process of implementation of solar rooftop in Odisha as an ideal process for the country. Based on the identified gaps and learning from national and international experience of implementing solar rooftops, key recommendations for OREDA and Odisha Discom are as follows

S. No	Key Steps	Gaps and Recommendations
1.	Information Access	<ul style="list-style-type: none"> <li>• In the existing framework of OREDA CRC, applicant has limited information with regards to installation of solar rooftop.</li> <li>• Information access is an important phase of project implementation and applicant should be available with all the required information with regards to <ul style="list-style-type: none"> <li>○ Project Planning</li> <li>○ Resource Assessment</li> </ul> </li> </ul>

---

	<ul style="list-style-type: none"> <li>○ Description of Key Equipment</li> <li>○ Standards and Specifications of Equipment</li> <li>○ Cost Economics</li> <li>○ Project financing</li> <li>○ State and Central Govt. Schemes</li> <li>○ List of vendors with price quotation for different size of projects etc.</li> </ul>
	<ul style="list-style-type: none"> <li>● <b><i>As a best practice, there should be a platform where an applicant can gather all the required information with respect to system planning and implementation of the same in Odisha.</i></b></li> </ul>
2. Application Process	<ul style="list-style-type: none"> <li>● In the existing framework, Application access is online but submission of application is still manual at discom end.</li> <li>● Submission of application at OREDA is online however, remaining process is done manually.</li> <li>● <b><i>Industry best practice suggests that application process should be completely online ( application access, submission)</i></b></li> <li>● Further, In the existing framework, applicant has to file separate application to OREDA for subsidy and to CESU for connectivity</li> <li>● <b><i>A single web-portal, from where application can be submitted and downloaded by all the required agencies (OREDA, CESU, and BMC) is highly recommended.</i></b></li> <li>● <b><i>At present there is no provision of online payment, Applicant should also be allowed to submit the processing fee through online mode.</i></b></li> <li>● <b><i>As per the current practice, there is no integration of OREDA, CESU and BMC, which is still to be explored</i></b></li> </ul>
3. Application Processing	<ul style="list-style-type: none"> <li>● As per the current practice OERDA goes for site inspection twice before and after project installation.</li> <li>● <b><i>To reduce the processing time and simplify the process, OREDA may consider Utility NOC as a proof of feasibility of rooftop system for issuance of subsidy approval letter.</i></b></li> <li>● <b><i>Later on, OREDA may go for site inspection jointly with utility during connectivity and synchronisation of solar rooftop before release of subsidy</i></b></li> <li>● <b><i>In the existing framework, there is no provision of online approvals (both at OREDA and discom), adoption of which could help in reduction of application processing time and also reducing administrative burden</i></b></li> </ul>
4. Feasibility Study	<ul style="list-style-type: none"> <li>● As per the current practice, Discom officials performs interconnection feasibility study both before and after the installation of project</li> <li>● This increases the processing time, moreover before installation of project, feasibility study (interconnection study) can be carried out without site inspection</li> </ul>

---

---

		<ul style="list-style-type: none"> <li>• <b>Best practice should be to adopt one time Interconnection feasibility study post installation of rooftop projects</b></li> <li>• <b>Further, for fast track application approval utility may also consider to omit the requirement of feasibility study for those consumer who are installing projects through selected/ empanelled vendors.</b></li> </ul>
5.	Interconnection Agreement	<ul style="list-style-type: none"> <li>• As per the current practice, discom has to sign interconnection agreement with applicant before starting project installation work</li> <li>• <b>By introduction of fast tract process, wherein projects below certain capacity say 10 kW are not required to sign interconnection agreement can reduce the time for processing of application</b></li> <li>• <b>Discom could also make interconnection agreement as a part of application form (for small consumers) so that the requirement of signing interconnection agreement can be omitted.</b></li> </ul>
6.	Subsidy Disbursement	<ul style="list-style-type: none"> <li>• As per the current practice there is no provision of subsidy disbursement through online mode.</li> <li>• <b>OREDA is recently planning to launch online subsidy process, which can be linked with AADHAR card so that subsidy amount can be directly transferred to beneficiaries account</b></li> </ul>
7.	Metering and Billing	<ul style="list-style-type: none"> <li>• Discom's Current Metering and Billing practice is not in line with net metering scheme, which is creating a huge confusion among rooftop consumers regarding settlement of excess power</li> <li>• Further, in Odisha billing is still done manually by utility officers, which increases administrative burden and also reduces billing efficiency</li> <li>• <b>Discom needs to upgrade their billing software to make it compatible with Net metering scheme</b></li> <li>• <b>AMR enabled meters and reading machines must be deployed to reduce the possibility of dispute in commercial settlement of net metering bill.</b></li> </ul>
8.	Vendor Empanelment	<ul style="list-style-type: none"> <li>• As per the current practice, empanelled vendors are not required to quote price of rooftop system and also the key component manufacturers they will be providing in given price range</li> <li>• <b>Best practice in this should be to seek price quotations from empanelled vendors based on capacity of the project such as (1-10 kW), (10-100 kW), (100-500 kW) as per MNRE guidelines for key components (Modules, Inverter, Meter etc.) every six months</b></li> </ul>

---

## 9 Annexure (Existing Formats)

### 9.1 Best Practices - Rooftop Solar Implementation

Establishing interconnection to the grid is a recognized as the biggest barrier to the deployment of solar rooftop projects in India. Stringent technical requirements, multiple utility checks, and prohibitive regulatory barriers are common obstacles faced by solar rooftop projects. Hence, it is always recommended to standardize and streamline interconnection processes so as to bring more efficiency to the whole process and reduce the time taken in providing approvals for interconnections. To suggest the best practice for proliferation of solar rooftop in Odisha, this section will focus on some of the model processes adopted globally and in India for interconnection of solar rooftop with grid.

#### 9.1.1 California (Rule 21) Interconnection Process

In USA, California was the second state to develop interconnection standards, with the establishment of Rule 21. The purpose of Rule 21 is to streamline and standardize California's interconnection procedures

**Figure 29: California Interconnection Process**

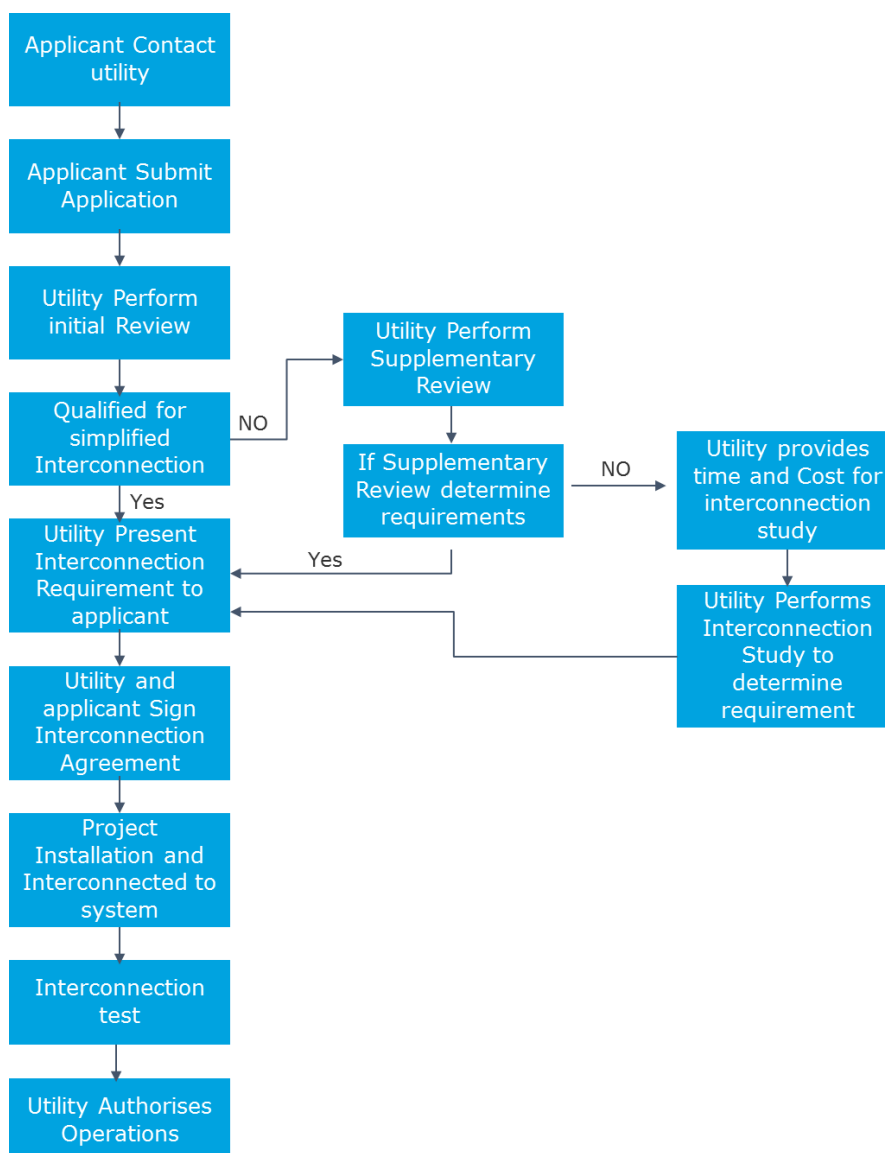

With establishment of Rule 21, California succeeded in reducing the processing time from 1 year to 3 months during first three years. Adoption of Rule 21 varies from utility to utility. Some utilities streamlined and simplified the interconnection procedures for small systems. For example, San Diego Gas and Electric (SDG&E) adopted an online combined net metering and interconnection application for systems 30 kW or less.

During the utility review process, all applicants follow the same screening process, irrespective of project capacity. Projects are assessed in an initial review based on eight screening criteria. Projects under 11 kW automatically satisfy three of the eight screens. Projects that pass the initial review qualify for a simplified interconnection. If systems do not qualify for a simplified interconnection, utilities have an opportunity to perform a review and determine what features and upgrades will be necessary for interconnection. Generally, PV systems under 10 kW are granted a simplified interconnection and do not require any supplemental review or interconnection studies.

After completing the utility review process, applicant sign an interconnection agreement with the utility. After this applicant can go ahead with installation and connection of solar rooftop with distribution grid.

The average time taken by different utilities for processing of interconnection request during 2010 is as follows

Utility	Average Time in processing of application
PG&E	16.0
SCE	5.9
SDG&E	3.1

Source: CPUC 2010

### 9.1.2 Germany Interconnection Process

In 2000, Germany passed the Renewable Energy Sources Act (EEG), which mandated utilities to prioritize connecting renewable energy projects to the grid. The interconnection process in Germany follows the same general process as in California, including the application, utility review, and commissioning. However, the major difference is that in Germany, there is no interconnection agreement or contract required from the applicant. Key Steps involved in the interconnection process followed in Germany is illustrated below.

**Figure 30: Germany Interconnection process**

Steps	For Small & Medium Scale Installation on Residential or Commercial Buildings (up to 50 kWp)
Application	Applicant files application for Grid Connection
Utility Review	Determination of Interconnection point by Utility (Interconnection Study is conducted where necessary)
	Grid Optimisation, upgrades and expansion by Utility (Where Required)
	Connection Point Proposal by Grid Operator
Interconnection Agreement	Grid Connection Agreement (Optional)
Installation & Commissioning	Connection of System and Commissioning
	Commissioning Protocol

For residential consumers, the first step toward interconnection is to submit the connection application to the utility, along with a site map, a circuit diagram, and technical data sheets on the modules and inverter. In the second step, the utility reviews the application to determine the connection point.

For projects of installed capacity up to 30 kWp, already connected to the grid, the existing connection point is used to connect the new PV system. However, in case the grid infrastructure is outdated, particularly rural areas, interconnection studies and grid upgrades may be required even for small systems. In case of grid upgradation, the charges for upgradation are paid by the utility. After receiving the interconnection request and performing the grid study, the utility submits a connection point proposal to the consumer. The final step is construction or installation of rooftop system, once the system is completely installed, it is connected with the grid by utility after test commissioning.

The average time for a utility to complete an interconnection study and submit a connection point proposal for a small, residential project is 4 weeks.

System Category	Minimum (Weeks)	Average (Weeks)	Maximum (Weeks)
Up to 5 kW	0	4	10
Above 5 kW to 50 kW	4	7	10
Above 50 kW	6	10	16

## 9.2 Karnataka Interconnection Process

In India, Karnataka was the first state that implemented interconnection process for solar rooftop in 2014. Since then there has been several modification and improvements has been done in the interconnection process to make it smoother and easier for utility and net metering consumers. Broad steps involved in interconnection of solar rooftop in Karnataka (BESCOM) are illustrated below

**Figure 31: BESCOM Interconnection Process**

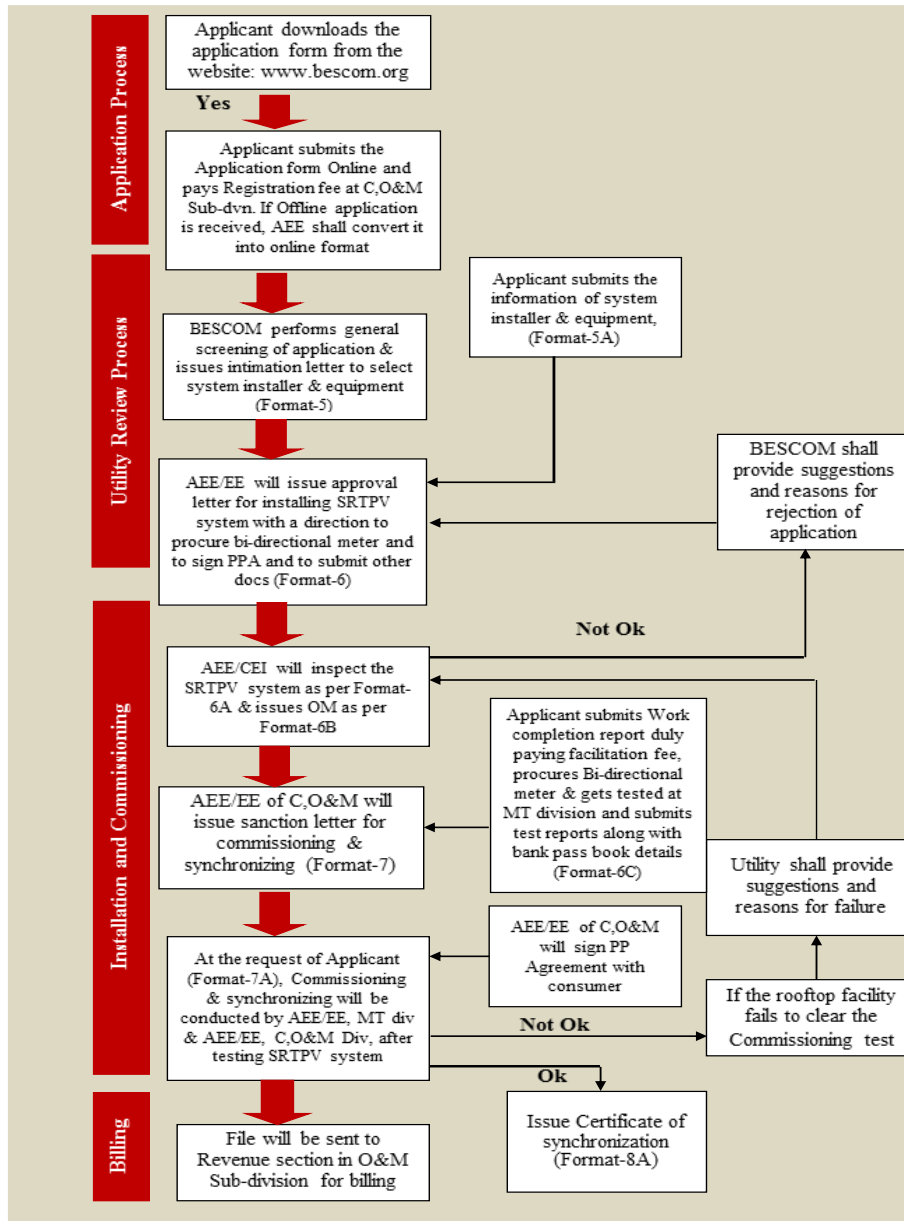

The first step toward interconnection in Karnataka starts with applicant submitting the connection application to the utility, along with a supporting documents such as site map, a circuit diagram, and technical data sheets on the modules and inverter. Thereafter, utility performs general screening of application. Post screening, the application is sent to field officer for technical feasibility. Post this, applicant signs interconnection agreement. After signing of Interconnection agreement, applicant execute PPA with utility after which it gets the approval for installation of rooftop solar projects. Post installation, applicant submits the work completion report and utility energizes the system. This whole process takes 210 days, wherein utility processing time is 30 days.

### 9.3 Implementation Models for Rooftop Solar

Rooftop solar interconnection arrangement defines the framework for connection of the rooftop solar system with the grid (utility). The choice of metering arrangement depends on its compatibility with the intended purpose of installation. The Metering and commercial settlement arrangement plays a pivotal role, as it affects

- Consumers' ability to sell excess/total power to the grid and receive payment
- Banking of power to use and adjust over a period of time
- Decision on system capacity etc.

Based on metering arrangement, the rooftop solar system can be categorized under two broad implementation models i.e. Gross-metered arrangement or Net-metered arrangement. The modalities in these arrangements are briefly described as below:

#### 9.3.1 Gross Metering Arrangement

The electricity is fed directly into the utility grid from the rooftop solar system and is metered at the utility interface point. There is no provision to feed the consumer loads from the rooftop solar energy generation. This is a preferred arrangement when the rooftop owner prefers to sell the entire generation to utility, generally by entering into PPA to sell electricity at Feed in Tariff (FiT) rate. The utilities can gain from the model in terms of meeting its Renewable Purchase Obligation (RPO), if any, or through lower bulk power purchase requirement. Utilities generally prefer to sign the PPAs with the aggregators to reduce the administrative burden. The following figure illustrates the typical gross metering arrangement

**Figure 32: Typical Gross metering arrangement**

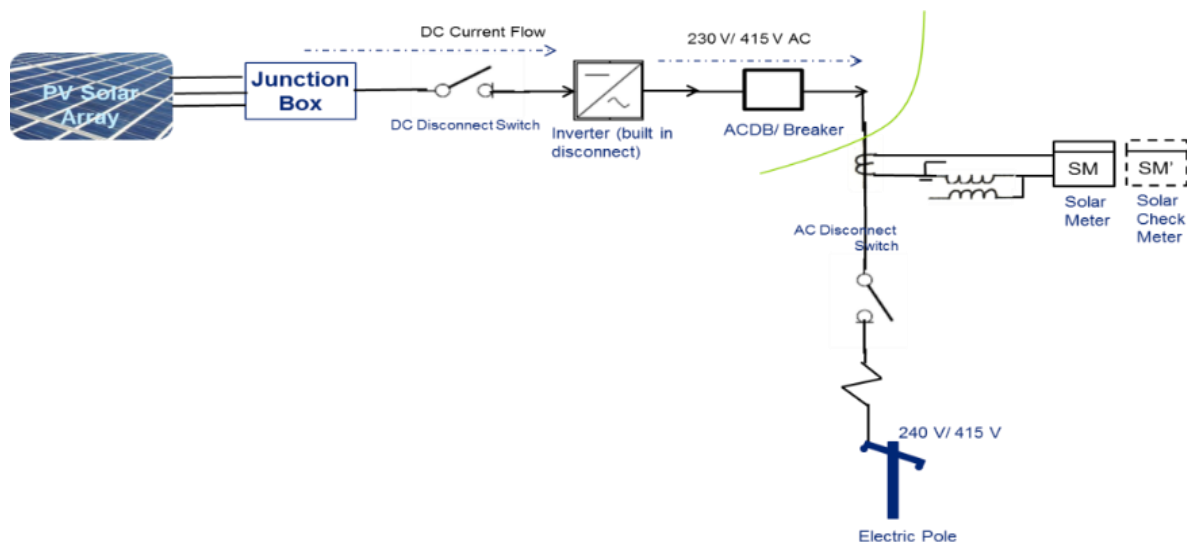

Source: Deloitte Research

#### 9.3.2 Net Metering Arrangement

The rooftop owners can meet their electricity requirement through the rooftop solar generation and can bank or sell the surplus energy to the grid. Under this arrangement, the solar meter installed at rooftop owner premises measures the generation while the net-meter measures the net of electricity consumed from the grid and the electricity fed to the utility. The consumer has the flexibility of generation and consumption at different points in time. The settlement of excess energy can be at the utility tariff or is considered as free energy by utilities at the end of settlement period, depending on the regulations which are prescribed by the Regulators. The following figure illustrates the typical net metering arrangement

**Figure 33: Typical Net metering arrangement**

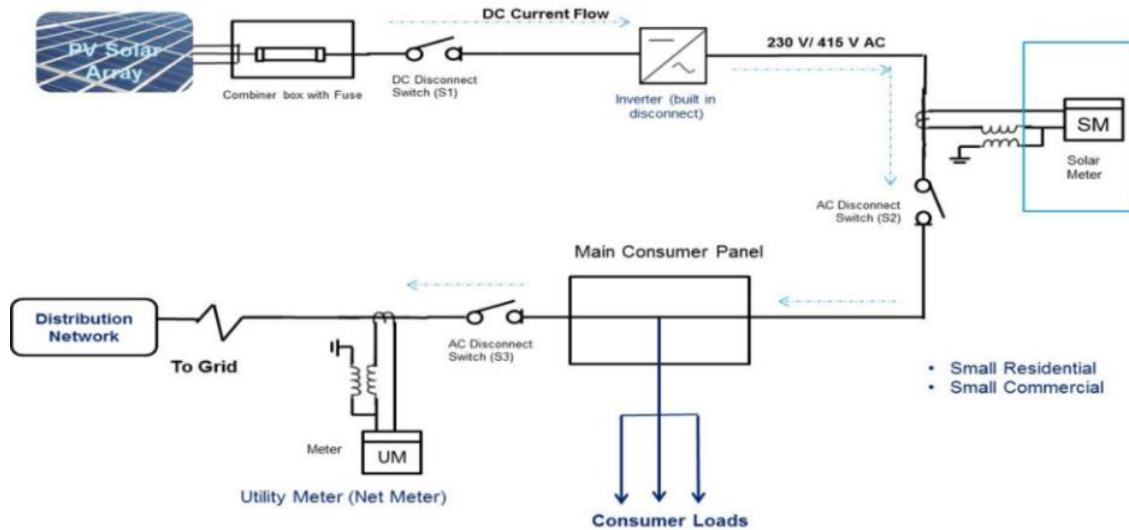

Source: Deloitte Research

### 9.3.3 Evolution of Rooftop Solar Business Models

A key driver of rooftop solar PV development across the globe has been the design and implementation of models which combine policy and regulatory frameworks with market dynamics to deliver bankable and sustainable projects.

Solar rooftop business models vary in terms of ownership (self-owned versus third-party-owned) and metering (gross versus net metering). The approaches used to support the emergence of the rooftop solar PV installations around the world can be split into two broad categories, based on the type of ownership of the installations:

1. **Customer side models – End-user Owned**
2. **Customer side models – Third party owned**
3. **Utility side models**

**Figure 34: Evolution of Decentralized Solar PV Models**

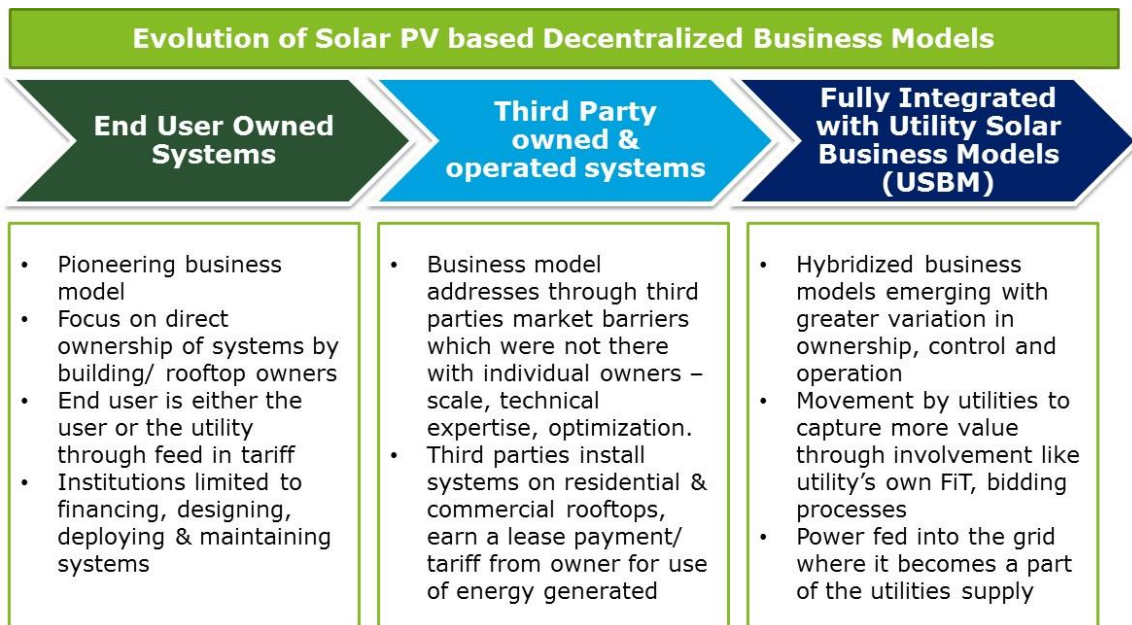

Source: Deloitte Research

#### 1 Customer side Rooftop Solar models

On the customer side implementation models, utilities are generally passive actors, with the role limited to provision of net metering and roll out of standardized and simplified interconnection schemes mandated by

regulatory requirements. Utilities have no role in the system operation itself. However, with growing solar PV market penetration, the scale of solar energy generated has an impact on grid operations, grid planning and utility profitability. This has led utilities to increase their participation in the customer side implementation

## **2 End user owned models**

Distributed solar generation models have become popular among consumers due to the declining cost of solar energy, proliferating fiscal incentives like feed-in tariff, net metering and tax rebates, and increasing tariffs for utility supply from the grid. Under the customer driven model, the customer owns the rooftop solar systems and utilizes the solar power generated mainly for meeting its captive consumption. In India, MNRE has an approved list of channel partners for facilitating the implementation of customer owned rooftop projects.

One of the key issues related to customer driven models are related to high upfront cost and financing challenges. In order to overcome this, the availability of financing in form of loans for grid connected rooftop solar systems is critical. The emergence of third-party owned models where a provider of turnkey or specialized services for rooftop solar PV systems is responsible for the rooftop system has led to proliferation of large sized rooftop solar projects.

## **3 Third party/ RESCO based models**

Under third party owned / Renewable Energy Service Company (RESCO) models, the third party controls the PV system as well as owns it. There is also the possibility of customer ownership combined with third-party control.

The third-party ownership model has been a driving force for rooftop solar market expansion in the U.S. In this model, a commercial company owns and operates PV systems on the consumer's rooftop.

Electricity generated from the PV system is either used by the customer ("solar leasing" model) or sold to customer ("solar PPA" model). The structuring of financing of the third-party model allows for developers or investors to reap the benefits of tax incentives.

Under solar leasing model, the customer does not pay the upfront cost of the rooftop solar system but instead leases the system by paying fixed monthly instalments over a specified period of time (typically 15-20 years) and consumes the electricity generated by the leased system at an agreed price.

Under solar PPA model, the third-party developer installs, owns, and operates the rooftop solar system and receives a PPA price from the customer for the electricity delivered through rooftop solar system.

In this model, the utility role remains mainly one of facilitation—primarily driven by regulatory or policy changes. The utility pays for electricity received from the rooftop solar system and is then allowed to recover these costs through traditional rate-making proceedings.

## **4 Utility-side Rooftop Solar models**

International experience indicates that electricity utilities have begun to offer their customers the option of owning solar power systems. In this model, utilities find a source of finance on behalf of its customers. The finance will be used either to install a large-scale solar project in which customers have a share, or to lend directly to customers.

There are different financing structures under the utility driven model. One of the options is that each participating customer pays a fixed monthly price to have shares in a local solar project. The customer receives the benefits from the project in the form of bill reduction based on the amount of the electricity that the solar project produces and the size of solar share that the customer chooses.

In the U.S., utilities are beginning to explore business models of installing and owning rooftop solar systems. The utility will install, own, and operate the systems sized 200 kW – 1 MW on leased rooftops.

Further based on the types of models and ownership, there could be multiple business models which are in existence today.

**Figure 35: Rooftop solar Business models**

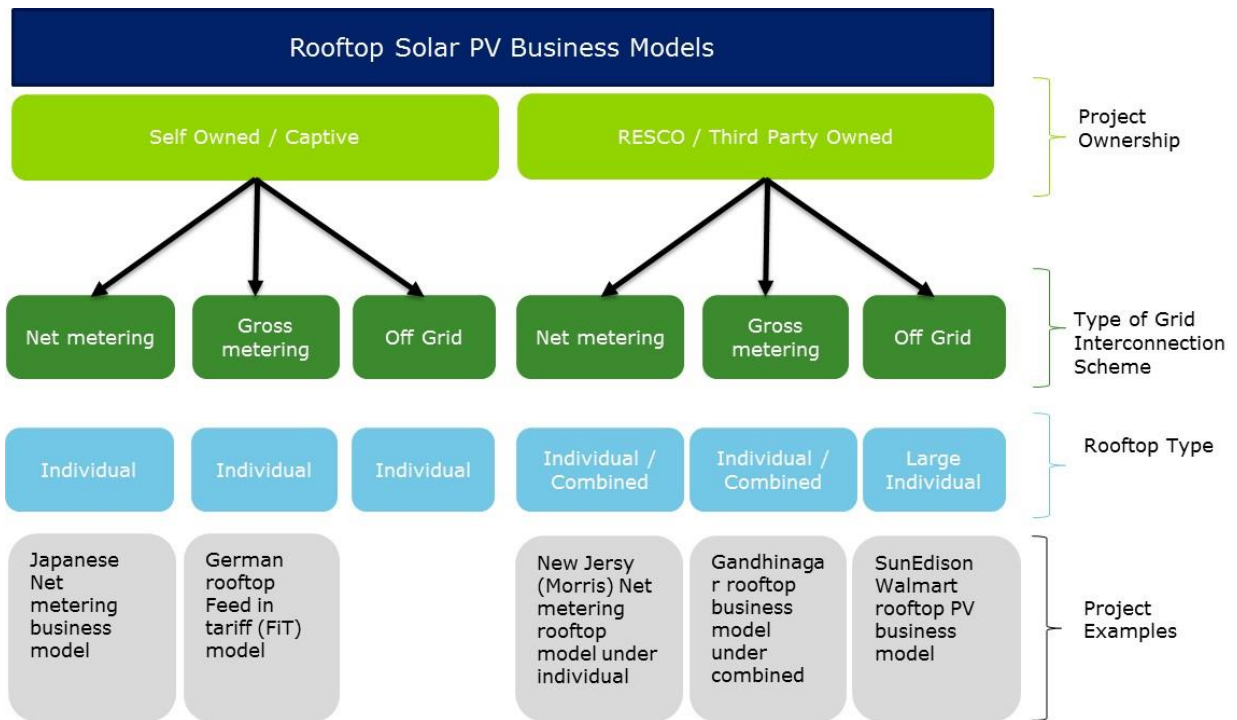

Source: Deloitte Research

## 9.4 Existing Formats for RTS Implementation

### 1 Vendor Empanelment Application Form

#### A. Vendor's Details

<b>1</b>	<b>Name of the Vendor</b>		
<b>2</b>	<b>Contact Details</b>	Address Line 1	
		Address Line 2	
		Address Line 3	
		City	
		State	
		PIN	
		Phone 1	
		Phone 2	
		Phone 3	
		Fax	
		Email	
		Website	
<b>3</b>	<b>Name of authorized Person for all Contacts by OREDA /Users</b>		
		Address Line 1	
		Address Line 2	
		Address Line 3	
		City	
		State	
		PIN	
		Phone 1	
		Phone 2	
		Fax	
Email			
<b>4</b>	<b>Category</b>	Company	
		Firm	
<b>5</b>	<b>Registration Details</b> ( Enclose Copy )	Registering authority	
		Registration No	
		Date of Registration	
		Place of Registration	
<b>6</b>	<b>Type</b> ( Enclose Copy )	Manufacturer	
		System Integrator	
<b>7</b>	<b>Accreditation Details</b> ( Enclose Copy )	Name of the Agency	
		Date of accreditation	
		Rating given	
		Valid through	
<b>8</b>	<b>Tax Registration Details</b> ( Enclose Copy )	VAT	
		OVAT	
		STCC	
		ITCC	

**B. Details of Technical and Financial Capability**

1	Types of PV systems manufactured /integrated by the Vendor	System 1		
		System 2		
		System 3		
		System 4		
2	Annual Capacity to manufacture/ Integrate Solar PV systems ( MW) ( Enclose Stores Details Certificate by Competent Authority )			
3	No/Capacity (MW) of PV systems installed so far	System 1	Nos	Cumulative Capacity
		System 2		
		System 3		
		System 4		
4	No/Capacity (MW) of rooftop PV systems installed so far	Nos	Cumulative Capacity (MW)	
5	Minimum Capacity of Roof-top PV Power Plant (single unit)installed (KW)			
6	Maximum Capacity of Roof-top PV Power Plant (single unit) installed (KW)			
7	Names of Major Customers	Customer 1		
		Customer 2		
		Customer 3		
		Customer 4		
		Customer 5		
8	Quality Assurance System adopted	Product		
		Compliance		
9	Annual Turnover ( in Rs Lakhs) in the business of Solar PV alone for last 3 years	Process compliance		
		Environmental Compliance		
		2014-15		
10	Amount of taxes deposited ( In Rs lakhs) during FY 2015-16	2013-14		
		2012-13		
		Tax 1		
		Tax 2		

		Tax 3	
		Tax 4	

**Signature of Applicant**

**Date:**

## 2 OREDA CRC - Application Form



[ABOUT CRC](#) [SCHEMES](#) [GRIEVANCES](#) [MEDIA](#) [BLOG](#) [CONTACT US](#)

[OVERVIEW](#) [FAQ'S](#) [CHECKLIST](#) **[CALCULATOR](#)**

### O-SPIN

Note – This programme will calculate solar power potential of your rooftop based on size of your roof, regulatory guidelines of OERC and connected load

#### Personal Information

Your Name

Your Address

Mobile Number

Mail ID

#### Rooftop Details

Do you have a rooftop  Yes  No

Is it shadow free  Yes  No

Unit of measurement of rooftop  Feet  Meter

Length

Breadth

% of Shadow free area

Total Area

Area available for installation

Capacity of Power plant based on roof size

### 3 OREDA CRC - Application Confirmation Notice

Dear Applicant,

Thank you for showing interest in installing 'Rooftop Solar System'. We received your request through our on-line registration portal. Adoption of renewable energy sources for our own energy requirements reduces the nation's dependency on fossil fuel and helps fight the negatives of climate change. And we hope through this installation together we begin a journey which will not only be financially rewarding to you but has far reaching impact on our environment. Find below the step by step procedure to help you successfully install the rooftop solar systems and also receive your entitlements from appropriate authorities.

#### **STEP 1:**

You first need to select and contact one of the empaneled vendors to help you with the installation and inform you about its cost and other details. [List of Empaneled Vendors](#)

#### **STEP 2:**

Upon finalizing the vendor and the investment you intend to make after deciding on the capacity of the RTS System, you need to apply to the Discom (CESU/ NESCO/ WESCO/ SOUTHCO) for getting a No Objection Certificate (NOC) for connecting the system to the grid and installation of a Net meter/Bi-directional meter. [Forms for application of NOC](#)

#### **STEP 3:**

Upon getting the NOC from the Discom, you can start procurement of the hardware and proceed with the installation process. Once the installation process is complete, you need to intimate OREDA/ DISTCOM to complete inspection of the installation. Issuance of 'Installation Report' will formally operationalize the installation. OREDA after scrutinizing the papers will issue you a customer number and from that instance, you can take the service of the Customer Relationship Centre of OREDA for your service issues. [www.odisharenewable.in](http://www.odisharenewable.in)

#### **STEP 4:**

Upon getting the 'Installation Report' you now can apply to OREDA for release of subsidy, if eligible; along with the information concerning the hardware and installation. In case you need any clarification you can contact us at [1800-345-7135, Bikash- 9438-016007, Srinivas- 9438-016008

This is a computer generated mail, not to be replied.

Regards,  
Team Leader,  
Customer Relationship Centre,  
OREDA, Bhubaneswar

**4 OREDA/Discom - Application Form for Offline Submission****Net Metering/Bi-directional Metering Connection Application**

To

The Section Officer/Designated Officer

Distribution Licensee

[Name of office]

Date:

I / we herewith apply for a solar energy net-metering/ bi-directional metering connection at the service connection for the Rooftop Solar PV Project of which details are given below;

1	Name of applicant	
2	Address of applicant	
3	Service connection number	
4	Telephone number(s)	
5	Email ID	
6	Rooftop Solar PV Project capacity (Watts)	
7	Solar PV Project inverter make and type	
8	Solar PV Project inverter has automatic isolation protection (Y/N)?	
9	Has a Solar Generation Meter been installed(Y/N)?	
10	Expected date of commissioning of solar PV Project	
11	Concerned safety requirement fulfilled (Y/N)	

**DECLARATION**

I do hereby declare that the information furnished above is true to my knowledge and belief.

Signature with Name:

Address:

**5 DISCOM - Application Fee Receipt**

**ACKNOWLEDGEMENT**

**Received the application for the grid connectivity of Solar Rooftop PV system**

**NAME:** \_\_\_\_\_

**DATE:** \_\_\_\_\_

**PLACE:** \_\_\_\_\_

**TIME:** \_\_\_\_\_

**Consumer No.:** \_\_\_\_\_

**Registration No.:** \_\_\_\_\_

**Application Fees (Rs 500/-) Paid or Not:** \_\_\_\_\_

**Solar Rooftop PV Plant Capacity:** \_\_\_\_\_

**Name of Officer**

**Signature**

**Designation**

**Seal**

**6 Applicant – Letter of Authorization for Trusts**

(For filling application for installation of SRTPV system on behalf of a Trust / Committee/ Co-operative etc.)

Date: \_\_\_\_\_

We \_\_\_\_\_(Name of Trust/ Committee/ Co-operative etc.), residing at \_\_\_\_\_ wish to install Solar Rooftop PV (SRTPV) system at \_\_\_\_\_ and We accept all the terms, conditions and stipulations mentioned in the application form, CEA/OERC regulation and its amendments order from time to time and any other formats laid down by the CESU for this purpose.

Mr/Ms \_\_\_\_\_ (Name of Official/Person), residing at \_\_\_\_\_ is hereby mutually authorized to accept on our behalf, all the terms and conditions (including all safety standards) of the CEA regulation/OERC net-metering regulations and its amendments from time to time regarding installation, commissioning and grid connectivity of SRTPV system mentioned under the Application form or any other format prepared in this behalf by CESU and to execute such documents, agreements and other writings as may be necessary or required for this purpose.

Further, the above authorized person namely Mr/Ms \_\_\_\_\_(Name with Contact Number) is also nominated as the contact person on our behalf for any matter relating to the Installation, Operation and Inspection of solar rooftop facility.

Signature

(With Stamp)

**7 Applicant – Letter of Authorization for Partnership Firms**

(For filling application for installation of Solar Rooftop Photo Voltaic system for partnership firms)

We \_\_\_\_\_ (Name of the Lead member of partnership firm), wish to install Solar Rooftop PV (SRTPV) system and We accept all the terms, conditions and Stipulations mentioned in the application form and any other formats laid down by the CESU for this purpose.

This partnership firm has been incorporated by M/s \_\_\_\_\_ [insert name of Lead Member of partnership firm], a Company incorporated under the laws of \_\_\_\_\_ and having its Registered Office at \_\_\_\_\_ (herein after called the “Member-1”, which expression shall include its successors, executors and permitted assigns) and M/s \_\_\_\_\_ a Company incorporated under the laws of \_\_\_\_\_ and having its Registered Office at \_\_\_\_\_ (hereinafter called the “Member-2”, which expression shall include its successors, executors and permitted assigns), M/s \_\_\_\_\_ a Company incorporated under the laws of \_\_\_\_\_ and having its Registered Office at \_\_\_\_\_ (hereinafter called the “Member-n”, which expression shall include its successors, executors and permitted assigns), [The applicant should list the details of all the partner firms] for the purpose of submitting request for installation of grid connected SRTPV system.

Further, the above authorized person namely Mr./Ms. \_\_\_\_\_ (Name with Contact Number) from \_\_\_\_\_ (Name of the partnership firm) is mutually authorized to accept on our behalf, all the terms and conditions (including all safety aspects) for installation of grid connected SRTPV program mentioned under the Application forms or any other format prepared in this behalf by CESU and to execute such documents, agreements and other writing as may be necessary or required for this purpose.

The above authorized person namely Mr./Ms. \_\_\_\_\_ (Name with Contact Number) is also nominated as the contact person on our behalf for any matter relating to the Installation, Operation and Inspection of solar rooftop facility.

For ready reference, a copy of Partnership agreement and letter of authorization is attached with the application letter.

**Signature of authorized Person**  
**(With Stamp of Lead Partner)**

**8 Applicant – Certificate for not Availing MNRE Subsidy**

This is to certify that \_\_\_\_\_(Name of applicant) have applied for installation of Solar rooftop PV system at our premise \_\_\_\_\_ (address) with capacity of \_\_\_\_\_(KWp/MWp) and have not availed any subsidy or grant from Ministry of New and Renewable Energy (MNRE) or from any other state and central agency in this regard.

I hereby also agree not to claim any subsidy or grant in future either from MNRE or from any other state /Central agency for the same.

Signature of the applicant

Name

Date and Place

## 9 DISCOM - Feasibility Check

Certified that I Divisional Engineer \_\_\_\_\_ Division along with EMR and MRT have personally verified the premises of the applicant on dated \_\_\_\_\_ at which the solar photovoltaic system is to be installed. The details of verification are as below:

Technical Feasibility Report for _____ KWp Solar Roof Top PV System (SRTPV) At _____				
Sl. No.	Parameter	Utility Observation		
<b>A</b>	<b>Applicant Details</b>			
1	Name of the Applicant			
2	Whether Consumer submitted Application form for the aforesaid SRTPV plant with application fees (Rs 500/-) as per OERC Net Metering Order			
3	Address			
4	Consumer Number			
5	Consumer Category			
6	Type of Connection: 1ph LT or 3 ph LT/HT			
7	Metering Details	Solar Meter	Net Meter	Check Meter
	Type of Meter (Whole Current/LTCT/HT/ Single Phase)			
	Meter Sl. No			
	MF			
	Line CT Ratio/Line PT Ratio			
8	contract demand of consumer			
9	Arrear, if any			
<b>B</b>	<b>Distribution Transformer Details</b>			
10	Capacity in KVA of DT from which the said consumer getting power supply			
11	Location			
12	Total Connected load in KW			
13	Tong Tester reading of current in all 3 phase and neutral			
14	Total Nos. of Solar rooftop photovoltaic (SRTPV) systems already connected to the Distribution Transformer in kWp			
15	Total Capacity of solar rooftop photovoltaic systems already connected to the Distribution Transformer in kWp (individual capacity may be mentioned)			

16	Whether the aforesaid solar rooftop power system of capacity...Kwp can be connected to our grid complying the limit of 75% of the capacity of the Distribution Transformer			
<b>C</b>	<b>Feeder Details</b>			
17	Name of the 11KV Feeder			
18	Type and size of Conductor/Cable			
19	Total connected load on the feeder in KVA			
20	Peak load on the Feeder in Ampere			
21	Name of the 33/11 KV Substation			
22	Total IPPs connected to 11 KV line (other IPPs including SRTPV)			
23	Capacity of 33/11 KV Power Transformer			
<b>D</b>	<b>Solar Rooftop PV Power Plant Details</b>			
24	Details of proposed power plant (a) Proposed capacity of the SPV Power Plant (kWp)  (b) Plant proposed at single site/multiple sites  (c) Interconnection with the electricity network at single point or multiple point			
25	Technical Specification and other particulars of <b>panel, grid end Inverter, interlocking system &amp; protective system etc.</b> submitted by the consumer (proposed to be installed) are in compliance with the IEC/BIS/IEEE/IS standards and consumer has complied with CEA/IEGC/OGC/MNRE/CERC/OERC /DISCOM (CESU) regulations/requirements with respect to safe, secure and reliable function of the said Solar PV Project.			
26	Whether the Test reports (submitted by the consumer) for the tests conducted as per IS/IEC standards			
27	Whether Consumer opts to purchase meter himself or from CESU	Solar Meter	Net Meter	Check Meter
28	Technical Specifications and other particulars of solar meters and Net meter/ bidirectional meters submitted by the consumer (proposed to be installed) are compiled to the IEC/BIS/IEEE/IS standards	Solar Meter <b>Yes/No</b>	Net Meter <b>Yes/No</b>	Check Meter <b>Yes/No</b>
29	Whether the Single Line Diagram of the SRTPV System(Submitted by the consumer indicating all the <b>Safety aspects</b> of Grid Connectivity) is OK for grid Connectivity	YES/NO (if it is no, state reasons for the same and suggest alternate arrangements )		
31	Any other necessary details with Remarks			
<b>FEASIBILITY</b>				

<b>Whether proposed SRTPV installation is technically feasible or not</b>	<b>Yes/No (if it is not feasible, state reasons for the same and suggest alternate arrangements required to evacuate power from the SRTPV system)</b>
---------------------------------------------------------------------------	-----------------------------------------------------------------------------------------------------------------------------------------------------------

I hereby certify that the above said Solar Rooftop PV system is technically feasible (Yes/No) and grid connectivity can be provided to this system (Yes/No).

Executive Engineer  
Designation and seal

MRT Officer  
Designation and seal

EMR Officer  
Designation and Seal

## 10 DISCOM - NOC for Project Installation

To,

(Name & address of the applicant)

**Sub: No Objection Certificate (NOC) for installation of \_\_\_\_\_ kWp solar RTPV system at \_\_\_\_\_**

**Ref: 1. Application Registration No. \_\_\_\_\_ dated: \_\_\_\_\_**

Sir/Madam,

With reference to your Solar rooftop application, NOC is herewith accorded for installation of Solar RTPV system of \_\_\_\_\_ kWp on your rooftop at \_\_\_\_\_ of Cons. Number \_\_\_\_\_ (having CD \_\_\_\_ and DT capacity\_\_\_\_) as per following terms and conditions:

1. You are requested to ensure that the service connection/ earthing/ metering/ inverter etc. must conform to the standards as specified by IEGC, CEA, OREC net metering Regulation. Further, all the safety standards must be ensured prior to the synchronization of the aforesaid Solar Rooftop PV Power Plant.
2. All the other components of Solar Rooftop system shall comply with applicable IS/IEC standards. List of Technical specifications of the SPV System with relevant standards is available in OREDA website for information. Copy of Test reports for the tests conducted as per IS/IEC standards and Technical specifications of SPV system shall be submitted along with Work Completion Certificate as per Format-7 before Commissioning.
3. You have to upgrade infrastructure (service main, earthing, meter with CT, upgrade) wherever required, at your own cost.
4. Calibrated Net/ Bi-directional meter shall be purchased from discom approved vendors (as per discom approved Technical specifications) and to be fixed at net-metering point.
5. If the proposed capacity of the solar rooftop system is within 1MWp, then, as per OERC Regulation, the Applicant/Developer shall provide evacuation facility up to the interconnection. The applicant shall use equipment such as Transformer, Conductor etc., as per discom's specification.
6. Name and address of the OREDA empaneled Chanel partner/ approved Inverter manufacturers and Bi-directional Meter vendors is available in the OREDA and CESU website respectively.
7. The Applicant shall provide check meters when the solar rooftop system is more than 20kWp.

(\*Please note that CESU shall not be held responsible for any legal disputes between the applicant and solar rooftop system installer arising out of the contract)

You are requested to submit the following documents after installation of Solar RTPV system:

- I. Test Certificate of Net/Bi-directional meter from MRT division, Discom.
- II. Copy of the Single Line Drawing of the SRTPV System indicating all the Safety aspects of Grid Connectivity.
- III. Copy of Test reports for the tests conducted as per IS/IEC standards and Technical specifications of SPV system shall be submitted along with Work Completion Certificate/Report as per Format-4 before Commissioning.
- IV. Safety Certificate from competent authority (approval of Chief Electrical Inspectorate, GOO. for capacity above 500 kWp).

This approval is valid for **90 days** from the date of this letter and the SRTPV system is to be commissioned within this period, failing which the approval will be treated as cancelled.

Yours faithfully,

Nodal Officer  
CESU Head Office

CC.  
Concerned EE  
Concerned SE  
OREDA  
GRIDCO

**11 Applicant - Work Completion Report**

**To,**  
The Executive Engineer (Ele),  
....., Division  
CESU

**Sub:** Submission of work completion report (to be submitted by the applicant) for System documentation requirements.

**Ref:** Your Registration/Application No.: ..... dtd:.....

**Sir,**

With reference to the above, I would like to submit the following Basic information of my Solar Rooftop PV System (SRTPV System) for your kind needful and request for arranging to Inspect and Commission at the earliest:

**A. Details of the Application:**

1	Application No. and date	
2	Application fees in Rs.	

**B. Details of the Solar PV Module:**

1	Model No.	
2	Total Capacity in kWp	
3	Make	
4	No. of Modules	
5	Capacity of each Module in kWp	
6	Date of Installation	
7	Date of Commission	

**C. Details of the Inverter:**

1	Name of the inverter (Type)	
2	Make	
3	Model No.	
4	Capacity	
5	Serial No.	
6	Input Voltage	
7	Output Voltage	
8	Date of Installation	
9	Date of Commission	

10	total No. of inverters	
----	------------------------	--

**D. Details of Cables: DC**

1	Make	
2	Size & Type	

**E. Details of AC Wiring:**

1	Make	
2	Size & Type	

**F. Details of the DC distribution box:**

1	Make	
2	Sl. No.	
3	DC Surge Protection Device	
4	MCB / Isolator quantity & capacity	

**G. Details of AC distribution box:**

1	Make	
2	Sl. No.	
3	AC Surge Protection Device	
4	MCB / MCCB quantity & capacity	

**H. Details of Earthing:**

1	Earth resistance (in ohms)	
2	Size of the Earth wire / flat*	
3	Two separate earthing points	

[Note:\* Earthing shall be done in accordance IS 3043-1986, provided that earthing conductors shall have a minimum size of 6.0 mm<sup>2</sup> copper wire or 10 mm<sup>2</sup> aluminum wire or 3mm<sup>2</sup> X 70 mm<sup>2</sup> hot dip galvanized steel flat]

**I. Details of the Bi-directional meter details (please enclose the test report of the bi- directional meter tested at MRT division, CESU)**

1	Make	
2	Serial No.	
3	Capacity	
4	Type/Model	

5	Single ph./Three ph.	
6	Line CT/ PT Ratio	
7	Date of Test by MRT, CESU	

**J. Details of the Caution signs** (Size of the caution label: 105 mm width X 20 mm height, with white letters on a red background)

1	Panels	
2	Inverters	
3	DC/ AC distribution box	

**K. Provision of manual and automatic switches: Yes / No**

**L. Whether Operation and Maintenance information:**

**Such as Do's and Don'ts are provided by the System Installer: Yes\*/ No\*.**

Certified that the above said SRPTV system was installed by me and the equipment used, comply with the Technical and Safety standards as specified by CESU.

Signature of the Applicant

Name and Signature of the System

Name and Address

Installer with Seal

Name: \_\_\_\_\_

Name of the firm and address: \_\_\_\_\_

\_\_\_\_\_

\_\_\_\_\_

Date: \_\_\_\_\_

Date: \_\_\_\_\_

**Enclosures:**

1. Test report of bi-directional meter tested at MRT division, CESU.
2. Copy of the IEC/IS Test certificate of PV modules, Inverter, Cable etc.
3. Data sheets/Drawing for the array mounting System.
4. Actual Single line wiring diagram of the SPV System.
5. Copy of Maintenance & Operation information provided by the System Installer.
6. Copy of Power Purchase Agreement on Rs.200/- stamp paper with CESU.

**12 DISCOM/Applicant - Net metering Agreement**

This Agreement is made and entered into at (location) on this (date) \_\_\_\_\_ day of (month) between The Eligible Consumer, residing at (address) as first party AND \_\_\_\_\_ Distribution Licensee (herein after called as Distribution Licensee) and having its registered office at (address) as second party of the agreement.

And whereas, the Distribution Licensee agrees to benefit the eligible consumer for the electricity generated from his Solar PV Project of capacity\_\_\_\_\_ watts and as per conditions of this agreement and net-metering/ bi-directional metering orders issued by the Odisha Electricity Regulatory Commission.

Both the party hereby agrees to as follows:

**1. Eligibility**

- 1.1 Eligibility for net-metering/ bi-directional metering has been as specified in the relevant order of the Odisha Electricity Regulatory Commission. Eligible consumer is required to be aware and understood, in advance, of the standards and conditions of his system for being integrated into distribution system in conformity with the order of the Commission and other conditions mentioned.

**2. Technical and Interconnection Requirements**

- 2.1 The eligible consumer agrees that his solar PV Project and net' metering/ bi- directional metering system will conform to the standards and requirements specified in the following Regulations and codes as amended from time to time.
  - I. CEA's (Technical Standards for connectivity of the Distributed Generating Resources) Regulations, 2013 and amendments thereto.
  - II. Central Electricity Authority (Installation and Operation of Meters) Regulation 2006 and amendments thereto.
  - III. OERC Distribution (Conditions of Supply) Code, 2004 and amendments thereto.
- 1.2 Eligible consumer agrees that he has installed / will install, prior to connection of Photovoltaic system to Distribution Licensee's distribution system, an isolation device (both automatic and inbuilt within inverter and external manual relays) and agrees for the Distribution Licensee to have access to and operation of this, if required and for repair and maintenance of the distribution system.
- 1.3 Eligible consumer agrees that in case of a power outage from Distribution Licensee's system the photo voltaic plant will not inject any power into Licensee's distribution system and also ensures that automatic isolation or islanding protection of Solar PV system.
- 1.4 All the equipment connected to distribution system must be compliant with relevant international (IEEE/IEC) or Indian standards (BIS) and installations of electrical equipment must comply with Central Electricity Authority (Measures of Safety and Electricity Supply) Regulations, 2010 and amendments thereto.
- 1.5 Eligible consumer agrees that licensee will specify the interface/inter-connection point and metering point.
- 1.6 Eligible consumer and licensee agree to comply with the relevant CEA regulations in respect of operation and maintenance of the plant, drawing and diagrams, site responsibility schedule, harmonics, synchronization, voltage frequency, flicker etc.,
- 1.7 Due to Distribution Licensee's obligation to maintain a safe and reliable distribution. system, eligible consumer agrees that if it is determined by the Distribution Licensee that eligible consumer's photovoltaic system either causes damage to and/or produces diverse effects on other consumers or Distribution Licensee's assets, eligible consumer will have to disconnect photovoltaic system immediately from the distribution system upon direction from the Distribution Licensee and correct the problem at his own expense prior to a reconnection.

**3. Clearances and Approvals**

- 3.1 The eligible consumer agrees to obtain all the necessary approvals and clearances (environmental and grid connected related) before connecting the photovoltaic system to the distribution system.

**4. Access and Disconnection**

- 4.1. Distribution Licensee shall have access to metering equipment and disconnecting means of photovoltaic system, both automatic and manual, at all times.
- 4.2. In emergency or outage situation, where there is no access to a disconnecting means, both automatic and manual, such as a switch or breaker, Distribution Licensee may disconnect service to the premise.

**5. Liabilities**

- 5.1. Eligible consumer and Distribution Licensee will indemnify each other for damages or adverse effects from either party's negligence or intentional misconduct in the connection and operation of photovoltaic system or Distribution Licensee's distribution system.

- 5.2. Distribution Licensee and eligible consumer will not be liable to each other for any loss of profits or revenues, business interruption losses, loss of contract or loss of goodwill or for indirect, consequential, incidental or special damages, including, but not limited to, punitive or exemplary damages, whether any of the said liability, loss or damages arise in contract, or otherwise.
- 5.3. Distribution Licensee shall not be liable for delivery or realization by eligible consumer for any fiscal or other incentive provided by the Central/State government beyond the scope specified by the Commission in its relevant Order.

**6. Commercial Settlement**

- 6.1 All the commercial settlement under this agreement shall follow the Net metering order issued by the OERC.

**7. Connection Costs**

- 7.1. The eligible consumer shall bear all costs related to setting up of photovoltaic system including metering and interconnection costs. The eligible consumer agrees to pay the actual cost of modifications and upgrades to the service line required to connect photovoltaic system in case it is required.

**8. Termination**

- 8.1. The eligible consumer can terminate agreement at any time by providing Distribution Licensee with 90 days prior notice.
- 8.2. Distribution Licensee has the right to terminate Agreement on 30 days prior written notice, if eligible consumer breaches a term of this Agreement and does not remedy the breach within 30 days of receiving written notice from Distribution Licensee of the breach.
- 8.3. Eligible consumer agrees that upon termination of this Agreement, he must disconnect the photovoltaic system from Distribution Licensee's distribution system in a timely manner and to Distribution Licensee's satisfaction.

In the witness, whereof of Mr. \_\_\_\_\_ for and on behalf of \_\_\_\_\_ (Eligible consumer) and Mr. \_\_\_\_\_ for and on behalf of \_\_\_\_\_ (Distribution Licensee) sign this agreement in two originals.

Eligible Consumer Name

Distribution Licensee Name

Address

Designation

Service Connection Number

Office Address

Witness to the execution  
on behalf of eligible consumers

Witness to the execution  
on behalf of Distribution Licensee

- 1. Name :  
Address :

- 1. Name :  
Address :

- 2. Name :  
Address :

- 2. Name :  
Address :

### 13 DISCOM - Inspection Report

Certified that I Divisional Engineer ..... Division, CESU along with EMR and MRT have personally inspected the .....kWp SRTPV system at.....on date..... The details of inspection report are as below:

<b>Inspection Report for ..... kWp Solar Roof Top PV System (SRTPV) at .....</b>		
<b>Sl. No.</b>	<b>Parameter</b>	<b>Utility Observation</b>
<b>A</b>	<b>Applicant Details</b>	
1	Name of the Applicant	
2	Application No./Registration No. with Date	
2	Address	
3	Consumer Number	
4	Consumer Category	
5	Type of Connection: 1ph LT or 3 ph LT/HT	
6	contract demand of consumer	
7	Arrear, if any	
<b>B</b>	<b>Distribution Transformer Details</b>	
1	Capacity in KVA	
2	Location	
3	Total Capacity of rooftop solar photovoltaic systems already connected to the Distribution Transformer in kWp (individual capacity may be mentioned)	
4	Whether the transformer capacity is adequate to deliver the proposed Solar rooftop PV system in addition to existing SRTPV systems	<b>Yes/No</b>
<b>C</b>	<b>Solar Rooftop PV Power Plant Details</b>	
1	Details of proposed power plant (a) Capacity of the SPV Power Plant (kWp)  (b) Plant proposed at single site/multiple sites  (c) Interconnection with the electricity network at single point or multiple point	
2	Whether the Single Line Diagram of the SRTPV System(Submitted by the consumer indicating all the Safety aspects of Grid Connectivity) is OK for grid Connectivity	<b>YES/NO</b> <b>(if it is no, state reasons for the same and suggest alternate arrangements )</b>
<b>D</b>	<b>Grid Tied Inverter</b>	
1	Make	
2	Serial No.	

3	Capacity		
4	Input Voltage/ Output Voltage		
5	Whether Anti-islanding feature is in working condition		
6	Date of installation		
<b>E</b>	<b>P.V Module</b>		
1	Make		
2	Serial No.		
3	Type of Module		
4	Capacity of each Module		
5	No. of Module		
6	Total capacity of Module		
7	Date of installation		
<b>F</b>	<b>Earthing Verification</b> <b>(i)D.C Earthing</b> <b>(ii)A.C Earthing</b>	<b>(i)....in Ohm</b> <b>(ii).....in Ohm</b> <b>Within permissible limit or Not</b>	
<b>G</b>	Details of protective system available	<b>(i) AC &amp; DC DB: Yes/No</b> <b>(ii) Manual Switch at Solar Side: Yes/No</b> <b>(iii)Relay operated automatic switch at net-meter side: Yes/ No</b>	
<b>H</b>	EIC inspection and approval letter Submitted by the consumer	<b>Yes/ No</b>	
<b>I</b>	Work Completion Report of SRTPV by consumer	<b>Yes/ No</b>	
<b>J</b>	Test report of all component of SRTPV system (including inverter) is as per CEA/OERC regulation and IS/ BIS standards	<b>Yes/NO</b>	
<b>K</b>	Meter Details	<b>Net Meter</b> <b>(Bi-directional Meter)</b>	<b>Solar</b> <b>Generation</b> <b>Meter</b>
1	Meter Make		
2	Meter Sl. No.		
3	1 Ph/ 3Ph		
4	Capacity		
5	Meter Constant		
<b>L</b>	Any other necessary details with Remarks		
<b>Inspection Report</b>			

<b>Whether proposed SRTPV installation is satisfactory for grid connectivity/ Synchronization</b>	<b>Yes/No (if it is not satisfactory, state reasons for the same and suggest alternate arrangements required to evacuate power from the SRTPV system)</b>
---------------------------------------------------------------------------------------------------	---------------------------------------------------------------------------------------------------------------------------------------------------------------

Executive Engineer  
Designation and seal

MRT Officer  
Designation and Seal

E&MR Officer  
Designation &Seal

**14 DISCOM - Approval Letter for Commissioning and Synchronization**

**To,**

(Name & address of the applicant)

**Sub:** Certificate for synchronization/ grid connectivity and Net (or Bidirectional metering) Metering facility of \_\_\_\_\_ kWp solar RTPV system at \_\_\_\_\_

**Ref:** 1. Application Registration No. \_\_\_\_\_ dtd: \_\_\_\_\_

**Sir/Madam,**

With reference to the completion report submitted by you and as per the safety certificate from competent authority submitted by you, Discom has conducted commissioning/synchronization test for \_\_\_\_\_ kWp Solar Rooftop PV Power Plant at \_\_\_\_\_ on dated \_\_\_\_\_ (having consumer No. \_\_\_\_ and Registration No. \_\_\_\_)

Based on these reports, your SRTPV system is found satisfactory and the said SRTPV system will be synchronized with CESU grid on date \_\_\_\_\_

However, you are requested to sign an agreement with CESU in the Standard Agreement Form (as per Form-2 of OERC Net Metering Order) prior to Synchronization/ grid connectivity and net metering.

**Yours, faithfully,**

**Divisional Manager**

**CESU**

C.C to  
CGM (Comm), CESU Head Office  
Head, OREDA  
Head Gridco

## 15 DISCOM Checklist for Grid Connectivity before Synchronization

- 1) For the feasibility of the Solar PV system, keeping in view of technical safety & grid security, the cumulative capacity of solar PV system is checked & it should not exceed 75% of the capacity of the distribution transformer from which it will draw the load.
- 2) The peak load of the 11KV feeder which feeds the distribution TRF is assessed.
- 3) The maximum load of the 33/11KV Power TRF, from which the 11KV feeder is drawing load, is monitored.
- 4) The capacity of an individual rooftop PV system is checked whether it is equal to the sanctioned load of the consumer & also the installation of bidirectional meter is checked to monitor the power flow of PV system.

### For Protection of Utility Equipment's

- **Harmonic Current:** The Harmonic Current Emission injected into Utility interface, while the inverter is operating at 100% rated Power.
  - 1) The total harmonics distortion shall be less than 5% of rated inverter output.
  - 2) The Even Harmonics shall be less than 25% of the next higher Odd harmonics (which is verified by Inverter Test Report).
    - a. 3rd through 9th harmonics:- distortion limit should be less than 4%
    - b. 11th through 15th harmonics:- distortion limit should be less than 2%
    - c. 17th through 21st harmonics:- distortion limit should be less than 1.5%
    - d. 23rd through 33rd harmonics:- distortion limit should be less than 0.6%
- **Synchronization:** The provision for grid frequency synchronization device for a Photovoltaic System is **checked from the test reports**, in such a manner that every time the generating system is synchronized to the electricity system, it shall not cause voltage fluctuation greater than +/- 5% at point of connection.
- **Voltage Variation:** The under voltage and over voltage levels with nominal frequency of the utility interface at which the inverter ceases to energize the utility line is **reviewed from the test reports**.
- **Islanding & Disconnection:** A PV system that ceases to energize the utility line in case of a fault condition or voltage & frequency variations outside the ranges along with tripping time frames considered to be sufficiently protected against islanding/disconnection is **physically checked by varying the tripping ranges of voltage & frequency**.
- **Over Load & Over Heat:** The response to Over load or out-of-range utility condition that has caused the PV system to cease energizing, the PV system shall not energize the utility line for 03 minutes after utility service voltage & frequency have recovered to within the specified ranges; the above said parameter is **verified by varying the load beyond its range**.
- All the above protection parameters are simultaneously reviewed from the test reports of the installed equipment; but could not be tested due to unavailability of Testing Instruments for the above purpose.

### The installation of protective devices is checked as summarized below:-

- 1) Surge Protection devices installed at the following places :
  - a. DC distribution box near solar grid inverter
  - b. AC distribution box near solar grid inverter
  - c. At the interconnection point to utility grid.
- 2) Automatic isolation of solar PV system within the required response time mentioned above achieved by the help of fast acting circuit breakers & disconnectors during no grid supply, low or over/under voltage conditions.

- 3) Isolating disconnecter switches in addition to automatic sensing & isolating on grid supply failure provided by the consumer to avoid possible accidents due to back feeding from solar PV system.
- 4) The solar grid inverter in built blocking features; in such a way that solar power/back up battery power/DG Power should not extend to utility supply system irrespective of LT connectivity in case of utility grid failure.
- 5) All of the metal in a PV system that could become energized during a fault (besides the current-carrying conductors) and connect them together to EGC (Equipment Grounding Conductor). Then connection of EGC to a separate earthing electrode.

**16 DISCOM - Commissioning and Synchronization Report****To,**

(Name &amp; address of the applicant)

\_\_\_\_\_

\_\_\_\_\_

**Sub:** Commissioning/ synchronization (grid connectivity) and Net (or Bidirectional metering) of \_\_\_\_\_ kWp solar RTPV system at \_\_\_\_\_

**Ref:** 1. Application Registration No. \_\_\_\_\_ dtd: \_\_\_\_\_

**Sir/Madam,**

Your Solar Rooftop PV system of ..... kWp, installed on the roof of your .....(consumer No.....and RR No.: ..... ) has been successfully synchronized with the CESU grid on date: .....  
....

**Meter Details:**

	Meter Details	Net Meter (Bi-directional Meter)	Solar Generation Meter
1	Meter Make		
2	Meter Sl. No.		
3	1 Ph/ 3Ph		
4	Capacity		
5	Meter Constant		
6	Initial Reading		
	Import		
	Export		
	Net		

You are requested to ensure the aforesaid Solar Rooftop PV Power System should comply with OERC net metering regulation & other CEA/CERC etc. regulation and its amendments order from time to time, including the followings, after its grid connectivity with discom network:

- (i) The cumulative Grid injection is capped at 75% of the distribution transformer capacity.
- (ii) Electricity generated from your solar rooftop PV Power System is capped cumulatively at 90% of the electricity consumption by the consumer at the end of a settlement period which ends with the financial year to allow for seasonality in generation.

Yours, faithfully,

Divisional Manager

CESU

C.C to

CGM (Comm), CESU Head Office

Head, OREDA

Head Gridco

## 17 Technical Standards for Solar Rooftop

Technical Standards to be followed for SRTPV Systems			
Item/ System/ Component	Applicable BIS /Equivalent IEC Standards/Applicable MNRE Specifications		
	Standard Description	Standard Number	
Solar PV Modules	Modules		
	i	Crystalline Silicon Terrestrial PV modules Thin film Terrestrial PV modules Concentrated PV Module	IEC 61215/IS14286 IEC 61646/ IS 16077 IEC 62108
	ii	Solar PV module safety qualification requirements	IEC 61730 (P1 ,P2)
	iii	PV modules to be used in a highly corrosive atmosphere (Coastal area etc.) must qualify Salt Mist corrosion Testing	IEC 61701/ IS 61701
	Each PV module must use RFID tag which must contain the following information as per MNRE requirements: i. Name of the manufacturer of PV Module ii. Name of the manufacturer of Solar Cells iii. Date of year of manufacture (separately for solar cells and module) iv. Peak wattage, Im, Vm and FF for the module v. Unique Sl. No. and model no. of the module vi. Date and year of obtaining IEC PV module qualification certificate vii. Name of the test lab issuing IEC certificate		
	WARRANTY: PV modules used in solar power system must be warranted for their output peak watt capacity, which should not be less than 90% at the end of 10years and 80% at the end of 15 years.		
	Grid tied inverters	i*	Environmental Testing (cold, Drt heat, Change of temp., Shock,Damp heat)
ii*		Efficiency Measurements (10%, 25%, 50%, 75% & 90-100% Loading condition)(For standalone system)	IEC 61683:1999
iii		Product safety standard	IEC 62109-1 (2010) IEC 62109-2 (2011)
iv		Grid Connectivity utility interface	IEC 61727:2004 (as per IEEE 519 specifications)
v		Test procedure for islanding prevention measures for utility/interconnected PV inverters	IEC 62116 or IEEE 1547 and IEEE 1547.1/ UL 1741
* Note: for testing sl. no. i & ii beyond 10KVA self-certification by manufacturers are acceptable in case if the Charge controller is not built-in the inverter, IEC 62093 test is required separately for Charge controller			

	vi	Electromagnetic compatibility & Electro Magnetic Interference	IEC 61000-6-1:2007 IEC 61000-6-3:2007 IEC 61000-3-2:2006 IEC 61000-3-3:2006
	vii	Ingress protection	IP 65 (for outdoor)/ IP 21 (for indoor) As per IEC 60529
Cables	General Test and Measuring Method PVC insulated cables for working voltage upto and including 1100 V and UV resistant for outdoor installation for A.C. cables.(It is suggested to use D.C. rated, UV resistant Photovoltaic cable having plug and play capability cables)		IEC 60227 / IS 694 IEC 60502 / IS 1554(part I & II)
Earthing	Grounding		IS 3043: 1986 IEC 62561 series(Part 1,2 and 7)
Surge Arrestors	Surge protective devices connected to low-voltage power systems - Requirements and test methods		IEC 61643-11:2011 IS 15086-5 (SPD)
Switches/Circuit Breakers/Connectors	General Requirements Connectors -safety A.C. /D.C.		IEC 60947 Part I,II, III / IS 60947 Part I,II, III / EN 50521
Junction Boxes/ Enclosures for Charge Controllers/Luminaries	General Requirements		<b>IP 65 (for outdoor)/</b> IP 21 (for indoor) As per IEC 60529
Solar PV Roof Mounting Structure	Material for the structure mounting		IS 2062/IS 4759

## 18 Empaneled Vendors with OREDA

S/N	Name of Vendors	Contact Person Name	Contact No.	Address
1	Aditi Solar Pvt. Ltd	Mr. V V Nagendra Yadali	8978854999	Plot No. N-5/345, Behind Jupiter Women's Science college, IRC Village, Nayapalli, Bhubaneswar – 751015, info@aditisolar.in
2	CIRA Renewable Energy Pvt. Ltd	Mr. Sushil Samantra	9439026733/9959 928085	HIG-7, Dharma Bihar, Khandagiri, Bhubaneswar-751030, sushil@cirarenewable.com
3	Environ Energy Corporation Pvt	Mr. Biswanath Das	7897998841	Church Lane, Ward no:17, PS-Sahadeb Khunta, Balasore-756001, biswanath@bhaskarsolar.com
4	Gayatri Engineering and construction Pvt. Ltd	Mr. Udit Mishra	9040082832	1717/2379, Sri Ram Nagar, Kapileswar Canal Road, Bhubaneswar-751002, gayatrisolar1@rediffmail.com
5	Greenco System Pvt. Ltd	Mr. Santosh Kumar Patra	9437022789 9437007870	Plot No: 47/4, 1st floor, Lane-2, Sastri Nagar, Bhubaneswar-751001, bobhubaneswar@gmail.com, greencosystemspvtltd@gmail.com
6	Jackson Engineering Ltd	Mr. Sakti Prakash Rana	9937139875/8895 629875	3rd Floor, Metro House. Vanivihar Square Bhubaneswar-751007, sakti.rana@jakson.com
7	KC Kopar Energy solution Pvt. Ltd.	Mr. Joseph T D	9438621364/9438 428192	HIG 50 (II Floor), Lumbini Vihar, Niladri Vihar, Chandrasekhar Pur, Bhubaneswar - 751 021, josejuby@rediffmail.com joe.kckopar@gmail.com
8	Kirti Solar Limited	Mr. Subhash Kr Acharya	8763719577	Plot No: 1C/57, Sector-9, CDA, Cuttack-753014, info@kirtisolar.com

9	Lycos India Limited		0674-2588608, 2588609	Lycos House, Plot No: 1438, Sector-A, Zone-A, Mancheswar Industrial estate, Bhubaneswar-751010, mktgbbsr@lycosind.com
10	Novus Green energy system Pvt. Ltd.	Mr. Devi Dash	9937681116/9338 108990	Corporate "Siddhi" Suite 1, 2nd florr, 100 P&T colony, Trimulgherry, Secunderabad-500015, Telengana, devidash@novusgreen.in
11	Premier Solar system Pvt. Ltd.	Mr. Deepak Ranjan Mansingh	7205016587	Survey No: 54/part, Above G Pulla Ready Sweet house, Vikrampuri colony, Karkhana Main Road, Secunderabad-500009, mansinghdeepak@yahoo.com
12	Shanti Associates	Mr. Vikas Kumar Bharlawala	9437035994	Metro Plaza, Phase-I, Ground florr, Barapathar, Buxi Bazar, Cuttack- 753001, ratankumar04@yahoo.com

**19 Grievance Redressal Form**

Name:

Email:

Subject:

Address:

Message: \_\_\_\_\_

## References

1. MNRE Achievement, Feb 2016  
<http://mnre.gov.in/mission-and-vision-2/achievements/>
2. MNRE Solar Rooftop targets  
<http://mnre.gov.in/file-manager/UserFiles/State-wise-and-year-wise-target-for-installation-of-40000MWp-GCRT-systems.pdf>
3. MNRE Scheme “ Off-grid and Decentralized Solar Application”  
<http://mnre.gov.in/file-manager/UserFiles/Scheme-Grid-Connected-Rooftop-&-small-solar-power-plants.pdf>
4. MNRE Subsidy Notification  
<http://mnre.gov.in/file-manager/UserFiles/gcrt-cfa-notification-04-03-2016.pdf>
5. MNRE Achievement Linked Incentive Scheme  
<http://mnre.gov.in/file-manager/UserFiles/Notification-Incentive-&-Award-scheme-for-Govt-Sector-30032017.pdf>
6. NISE Solar Potential State Wise  
<http://mnre.gov.in/file-manager/UserFiles/Statewise-Solar-Potential-NISE.pdf>
7. IREDA Loan Scheme  
<http://mnre.gov.in/file-manager/UserFiles/IREDA-Solar-PV-Loan-Scheme.pdf>
8. RBI Notification on making Renewable Energy priority lending sector  
<http://mnre.gov.in/file-manager/UserFiles/RBI-Notification-of-Priority-Sector-Lending-Targets-&-Classification-23042015.pdf>
9. Banks providing loan for Solar Rooftop  
<http://mnre.gov.in/file-manager/UserFiles/financing-of-Solar-Rooftop.pdf>
10. Odisha RE policy,2016  
<http://energy.odisha.gov.in/PDF/2178.pdf>
11. Development of Bhubaneswar Solar City  
[http://mnre.gov.in/file-manager/UserFiles/Master-Plan-Solar-City/Bhubaneswar\\_solar\\_city\\_master\\_plan.pdf](http://mnre.gov.in/file-manager/UserFiles/Master-Plan-Solar-City/Bhubaneswar_solar_city_master_plan.pdf)

## **ABOUT ECO-CITIES INDIA PROGRAM**

Eco-Cities India is a multi-year technical advisory program under the EU-India Cooperation on Clean Energy and Energy Efficiency that is focused on five Indian cities – Bengaluru, Bhubaneswar, Chennai, Mumbai Metropolitan Region, and Pune Metropolitan Region. The Program aims to regulate the efficient use of resources and promote the acceptance of clean energy for a sustainable future. The program has advisory interventions in four key sectors of city urbanization - transport, green buildings, water and waste management, and energy efficiency and renewable energy.

## **ABOUT IFC**

IFC, a member of the World Bank Group, is the largest global development institution focused on the private sector in emerging markets. Working with more than 2,000 businesses worldwide, we use our capital, expertise, and influence to create markets and opportunities in the toughest areas of the world. In FY17, we delivered a record \$19.3 billion in long-term financing for developing countries, leveraging the power of the private sector to help end poverty and boost shared prosperity. For more information, visit [www.ifc.org](http://www.ifc.org)